

GSA1系列自动转换开关适用于额定工作电压AC400V，频率50Hz额定电流从630A~6300A的双电源供电系统（常用电源和备用电源或常用电源和发电电源）中，因一路电源发生异常而进行电源之间的自动切换，以保证其供电的连续性和可靠性。该装置具有欠压、过压、缺相、过载和短路保护功能。广泛应用于医院、商场、银行、化工、冶金和高层建筑等重要的用电场所。

本装置执行 GB/T14048.11-2002《自动转换开关电器》、GB/T14048.1-2000《低压开关设备和控制设备 总则》和GB14048.2-2001《低压开关设备和控制设备 低压断路器》标准，同时符合IEC60947-2《低压开关设备和控制设备 第二部 低压断路器》的要求。

本装置使用类别为AC-33iB，级别为CB级。

GSA1 series automatic transfer switching equipment is used to shift from the abnormal power supply to in case of one line of abnormal power supply (normal power and reserve power or normal power and generating power), both of which have the rated operational voltage of AC400V, 50Hz, rated current of 630A to 6300A, So that reliability and continuous are ensured, this switch with undervoltage, overvoltage phases missing, overload and short circuit protection, this switch often used in hospitals, shopping malls, banks, chemical industry, metallurgy, building other important sites electricity.

this switchgear performs the standard of GB/T 14048.11-2002《Automatic transfer switching equipment》、GB/T14048.1-2000《Low-voltage switchgear and controgear--General rules》and GB14048.2-2001《Low-voltage switchgear and controgear--Low-voltage circuit breakers》，IEC60947-2《Low voltage switchgear and controgear second part--Low-voltage circuit breakers》.

The category of utilisation and class of this this switchgear are AC-33iB and CB.

型号及含义

TYPE AND MEANING

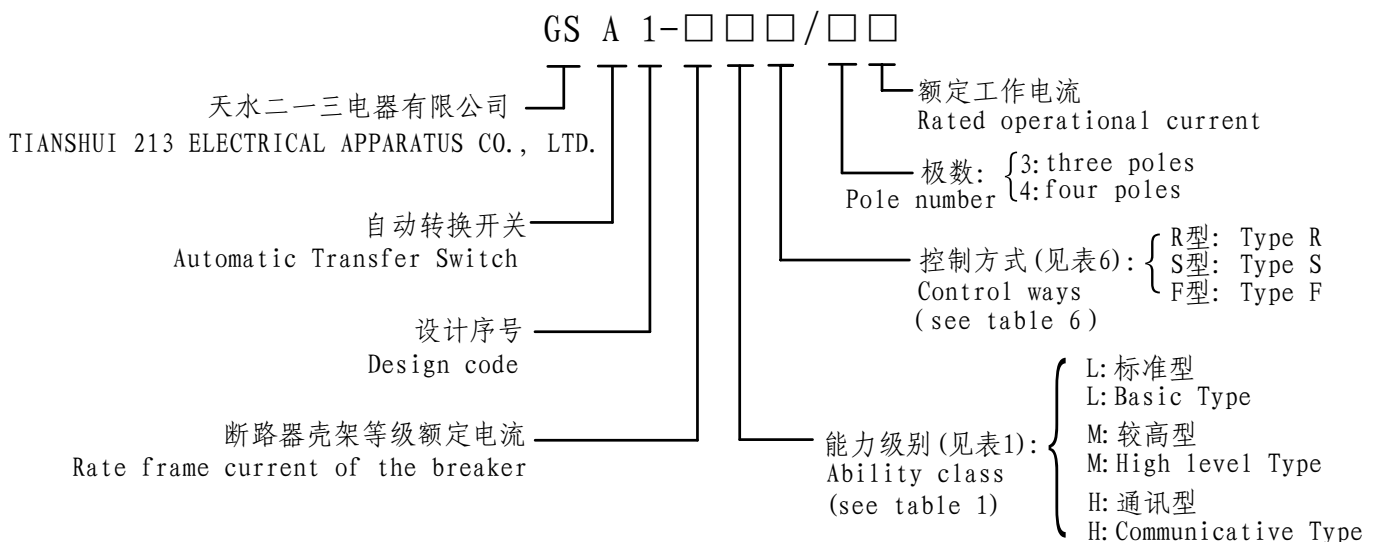

型号及含义

TYPE AND MEANING

表 1 Table1

能力级别 Ability class	功能说明 function explanation
L型 Basic Type	配L型GSW1框架断路器 Equip GSW1 L type breaker
M型 High level Type	配M型GSW1框架断路器 Equip GSW M type breaker
H型 Communicative Type	配H型GSW1框架断路器，有通讯接口功能 Equip GSW1 H type breaker , and communication interface function

使用环境

USE OF ENVIRONMENT

● 相对湿度在 + 40℃ 时不超过 50%，最湿月平均最低温度不 + 25，且该月平均最大相对湿度不超过 90%，对因温度变化发生在产品表面上的凝露应采取处理措施；

● The relative humidity of the air isn't above 50% at the max, temperature of +40℃, average temperature isn't above +25℃ at the max, humidity, and the average relative humidity isn't above 90%, Dew on switch due to temperature alteration should be removed.

● 主电路安装类别 IV，辅助电路的除了电源变压器初级线圈安装类别为 IV，其余安装类别为 III。

● IV for the major circuit and III for auxiliary circuit except undervoltage release and primary circuit of transformers, whose installing categories is IV.

● 周围空气温度为 - 5℃ ~ + 40℃，且 24 小时的平均值不得超过 + 35℃；

● The ambient temperature is - 5℃ ~ + 40℃ and the average value within 24 hours isn't above +35℃

● 安装时海拔不得超过 2000m；

● The elevation isn't above 2000m.

● 污染等级为 3 级；

● Pollution protection: grade 3.

● 液晶显示: 可显示铭牌页面、参数设定页面、运行页面、故障记忆等页面, 每个页面显示一个不同的功能, 通过显示屏和按键可以实现人机对话。

● 密码锁定: 凡与设定有关的参数均有密码保护。如需要修改参数, 必须将密码设置正确后才能进行修改。

● 参数设定: 欠电压值、过压电值、转换动作时间可自由设定。

● 三合一工作方式: 将R型、S型、F型集成于一台控制器中, 用户可在现场根据实际需要选择控制器的工作方式。

● 故障报警: 当常用电源或备用电源出现欠压、过压、缺相、过载和短路故障时, 对应的信号灯闪烁报警。

● 故障记忆功能: 可记忆上次出现的故障电源(常用电源或备用电源)、故障类型(过压、欠压、缺相、失压)和故障电压的最高值和最低值, 以及故障的最大电流相。

● 双断功能: 在发生火灾或其它紧急情况下, 可同时断开常用和备用电源, 使两个电源均无法向电路供电。

- 过电流和接地保护功能。
- 负载监控功能。
- 模拟试验功能。

● LCD displays: Nameplate pages can be shown, setting parameters pages, running pages, memory pages and so on, each page shows a different function, man and machine can be achieved to dialogue on display and buttons.

● Password setting: setting parameters have password-protected, if changes of parameters that must be set the correct password after amendment.

● Setting parameters: under-voltage value, over-voltage value, conversion time (t1-t6) for action can be set free.

● Three unite one of the way: type R, type S, type F work in an integrated controller, users may choose work mode of controller at scene.

● Error alarm: when normal power and reserve power appear undervoltage, overvoltage, phase missing, short-circuit and overload failure, corresponding lights alarm flashing.

● Error memory function: it can memory last power error (normal power or reserve power), fault type (overvoltage, undervoltage, lost voltage, lacking phase), error max voltage and min voltage, error max current.

● Dual-off function: in the event of a fire or other emergency situations, normal power supply and reserve power supply switch off, two power unable to operate.

- Overcurrent and earth protection.
- Load monitoring protection.
- Simulation test protection.

GSA1自动转换开关是由两台框架式断路器本体, 转接器和控制器三大部分组成的自动切换装置, 本体和控制器各自独立, 本体安装在电柜中, 控制器安装在电柜门上, 两者之间通过转换器用电缆线联接, 外形见图1。

GSA1 automatic switch is the automatic switching devices that consists of the frame breakers and controller, the main body and the controller are independence, the main body are mounted in cabinet, the controller is mounted on panel door. cable is used to link the main body with the controller by switching unit.



图 1 figure 1

● 断路器本体:

由触头系统、智能控制器、手动操作机构、电动操作机构和附件组成。 本体有固定式和抽屉式两种。

● Body of breaker:

the body of breaker consists of contacts system, intelligent controller, hand operating device, motor-driven energystorage system and attachments. body have fixed and draw-out.

● 固定式断路器(见图2):

由断路器本体、二次回路接线端子、安装板、相间隔板(带有相间隔板支架)组成。

● Fixed breaker(see figure 2):

It consists of body of breaker, secondary plug and socket units, installation plates, barrier between phases(with the fixture).

● 抽屉式断路器(见图3):

由断路器本体、抽屉座、相间隔板、手柄组成。

● Draw-out breaker(see figure 3):

It consists of body of breaker, draw-out socket, barrier between phases, handle.

● 抽屉座(见图4):

三个工作位置:“连接”位置、“试验”位置、“分离”位置。

● Draw-socket(see figure 5):

three working position: "connect" position, "test" position, "seperated" position.

▲“连接”位置:主回路和二次回路均接通;

▲"connect" position: main and auxiliary circuit are both "on";

▲“试验”位置:主回路断开,有绝缘板隔开,仅二次回路接通,可进行一些必要的动作试验;

▲"test" position: the main circuit is "off", safety seperator is closed, only auxiliary circuit is "on", the necessary action test could be done;

▲“分离”位置:主回路与二次回路均断开,此时即可拉出断路器本体部分;

▲"seperated" position: the main and auxiliary circuit are both "off", and the body of breaker could be pull out.

▲断路器只有在连接位置或试验位置才能合闸而在连接或试验的中间位置断路器不能合闸。

▲the breaker could be closed only in connect or test position and it can not be closed in the middle position.



图 2
figure 2



图 3
figure 3



图 4
figure 4

技术参数

TECHNICAL PARAMETERS

● 技术参数见表2

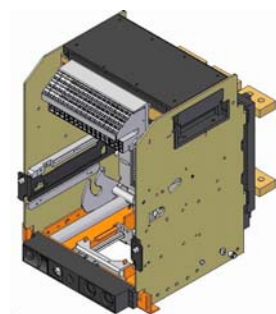
● Technical parameters see table 2

表2 table 2

型号 Type	GSA1-1600		GSA1-2000		GSA1-3200		GSA1-4000		GSA1-6300	
极数 Pole number	3极 three poles 4极 four poles		3极 three poles 4极 four poles		3极 three poles 4极 four poles		3极 three poles		3极 three poles 4极 four poles	
能力级别 Ability class	L, M, H		L, M, H		L, M, H		L, M, H		L, M, H	
控制方式 Control ways	R, S, F		R, S, F		R, S, F		R, S, F		R, S, F	
执行断路器 The mounting breakers	GSW1-1600		GSW1-2000		GSW1-3200		GSW1-4000		GSW1-6300	
额定工作电流 (A) Rated working current (A)	200、400、630 、800、1000、 1250、1600		630、800 1000、1250 1600、2000		2000 2500 3200		4000		4000 5000 6300	
额定工作电压 (Un) Rated working voltage (Un)	AC400V		AC400V		AC400V		AC400V		AC400V	
额定极限短路分断能力 Icu (KA) (有效值) Limited Short-circuit Breaking Capacity Icu(KA) (effective value)	65		80		100		100		120	
额定运行短路分断能力 Ics (KA) (有效值) Operation Short-circuit Breaking Capacity Ics(KA) (effective value)	55		50		65		65		100	
额定短时耐受电流 Icw (KA) /1s (有效值) Rated Stand Current For Short-time (1s) Icw (effective value)	55		50		65		65		100	
额定绝缘电压 (Ui) Rated insulation voltage (Ui)	AC1000V									
额定冲击耐受电压 Uuimp (V) Rated Impulse Withstand able Voltage Uuimp (V)	12000									
工频耐受电压 (V) Working Frequency Withstand able Voltage (V)	AC3500V 1min 50Hz									
额定频率 (Hz) Frequency (Hz)	50Hz									
欠压 (V) under voltage (V)	欠压值可现场调整 (1-220V), 级差1V。 Under voltage value can be adjusted at the scene(1-220V), grading is one									
过压 (V) Over voltage (V)	过压值可现场调整 (220-999V), 级差1V。 Over voltage value can be adjusted at the scene(220-999V), grading is one.									
失压 (V) lost voltage (V)	有三相全部小于66V All three phase are less than 66V									
缺相 lost phase	有一相小于66V A phase is less than 66V									
机械寿命 (次) Mechanical life (number)	15000		15000		10000		10000		4000	
电气寿命 (次) Electric life (number)	6500	3000	6500	3000	3000	1500	3000	1500	500	500
使用类别 Applicable catelogy	AC-33iB									

- 断路器过电流保护特性参数
- 断路器的整定值(见表3)

- Over-current protection feature parameters for breaker
- The setting value of breaker(see table 3)

表3 table 3

GSW1	长延时 long-delay			短延时 short-delay			瞬时 instantaneous		接地(零序) earthed (N-phase)		
	Inm (A)	Ir1	动作时间精度 fineness of acting time	显示精度 fineness of show	Ir2	动作时间精度 fineness of acting time	显示精度 fineness of show	Ir3	显示精度 fineness of show	Ig (IN)	动作时间精度 fineness of acting time
1600	(0.4~1) In	±15%	±5%	(0.4~15) In max: 50KA	见表5 see table 5	±15%	1.0In-50KA	±20%	(0.2-1) In (min: 160A)	见表5 see table 5	±10%
2000	(0.4~1) In	±15%	±5%	(0.4~15) In max: 50KA	见表5 see table 5	±15%	1.0In-50KA	±20%	(0.2-1) In (min: 160A)	见表5 see table 5	±10%
3200	(0.4~1) In	±15%	±8%	(0.4~15) In max: 50KA	见表5 see table 5	±15%	1.0In-50KA	±20%	(0.2-1) In	见表5 see table 5	±10%
4000	(0.4~1) In	±15%	±8%	(0.4~15) In max: 50KA	见表5 see table 5	±15%	1.0In-50KA	±20%	(0.2-1) In	见表5 see table 5	±10%
6300	(0.4~1) In	±15%	±10%	(0.4~15) In max: 50KA	见表5 see table 5	±15%	1.0In-100KA	±20%	(0.2-1) In	见表5 see table 5	±10%

- 长延时过电流保护反时限动作特性
1.05Ir1 < I ≤ Ir2 为反时限动作, 按 I²TL = (1.5Ir1)²tL 曲线动作, 见图5, 其中 (1.05-2.0) Ir1 的动作时间见表4。

- Inverse Long-delay Action Feature For Over-Current
1.05Ir1 < I ≤ Ir2 Inverse Action action according to the curve, whose formula is I²TL=(1.5Ir1)²tL, as table 5 show, and acting time in (1.05-2.0) Ir1 like table 4.

表4 table 4

电流 Current	动作时间 (t) Acting Time						
	1.05Ir1	2小时内不动作 No acting in 2h's					
1.30Ir1	<1h 动作 <1h acting						
1.50Ir1	t (s)	15	30	60	120	240	480
2Ir1	t (s)	8.4	16.9	33.7	67.5	135	270

tL-长延时1.5Ir1时整定时间
Ir1-长延时整定电流
In-断路器额定电流
TL-长延时动作时间

tL-setting time of long-delay 1.5Ir1
Ir1-setting current of long-delay
In-rated current of circuit breakers
TL-acting time of long-delay

- 短延时动作特性
当 Ir2 < I ≤ 8Ir1 时, 且 I²t = Y, 则保护特性为短延时反时限; 按 I²t1 = (8Ir1)²ts。
当 Ir2 < I ≤ 8Ir1 时, 且 I²t = N, 则保护特性为短延时定时限, 定时时间见表5。
当 8Ir1 < I ≤ Ir3 时, 则为短延时定时限特性, 其定时限特性见表5。

- Short-delay Action Feature
Ir2 < I ≤ 8Ir1 and I²t=Y, with the formula I²t1=(8Ir1)²ts, The protection is Inverse short-delay action feature.
Ir2 < I ≤ 8Ir1 and I²t=N, The protection is definite action feature and the definite time as table 5 show.
8Ir1 < I ≤ Ir3, The protection is definite action feature and the definite time as table 5 show.

表5 table 5

设定时间(S) setting time	0.1	0.2	0.3	0.4
动作时间(S) acting time	0.05 ~ 0.15	0.15 ~ 0.25	0.25 ~ 0.35	0.35 ~ 0.45

● 瞬时动作特性

当 $I > I_{r3}$ 时，为瞬时动作特性，动作时间为 20ms 左右。

● Instantaneous Action Feature

when $I > I_{r3}$, it becomes instantaneous action feature, and the action time is about 20ms.

● 接地故障保护特性

当 $I_g \leq I < I_{r1}$ 时，为接地保护特性，其接地保护特性见图 6。

● earthed error protection feature

when $I_g \leq I < I_{r1}$, it is the earthed error protection feature, and the protection feature seeing the chart 6.

● 零序电流保护特性

对四极或 3P+N 型断路器：当 $I_N \leq I < I_{r1}$ ，为零序保护特性，其保护特性见图 6。

● N-phase current protection feature

just for the type of 4P or 3P+N breakers, when $I_N \leq I < I_{r1}$, it is the N-phase current protection feature, and the protection feature seeing the chart 6.

● 负载监控特性

负载监控功能主要用于监控下级不重要负载，以保证主系统供电的稳定性。有两种工作方式：方式一和方式二。

方式一：当运行电流超过设定值时，控制器发出接点信号，相继断开负载 1 和负载 2。

方式二：当运行电流超过设定值时，控制器发出接点信号，相继断开负载 1 和负载 2，如果电流降到设定值以下，控制器可再发出信号，恢复已卸负载供电。

● Load Monitoring Feature

Load Monitoring Feature is used to monitor and control the subordinate unimportant load, as to ensure the stability of power supply of main system. there are two working patterns: pattern 1 and pattern 2.

pattern 1: when the operating current rises over the setting value, the controller sends out connection signal, and breaks off the load 1 and load 2 successively.

pattern 2: when the operating current rises over the setting value, the controller sends out connection signal, and breaks off the load 1 and load 2 successively. but when the current falls below the setting value, the controller could send out another signal to revert power supply to the load which was broken off.

● 特性曲线

特性曲线包括断路器的动作特性曲线（过载长延时，短路反时限，短路定时限、瞬时，见图 5）、接地保护特性曲线（见图 6）。

● Feature Curves

the feature curves include breaker's action feature curve (overload long-time delay, short circuit inverse time, short circuit definite time, instantaneous. see the chart 5), earthed protection feature curve (see the chart 6).

● GSW1 的智能控制器使用见《GSI-3 系列智能控制器使用说明书》。

● The Intelligent Controller used of GSW1, For details see 《Instruction of GSI-3 Series Intelligent Controller》.



图 5 过电流保护特性
table 5 over-current protection character



图 6 接地保护特性
table 6 earthed protection character

- GSW1断路器互感器的接线图
- Wiring diagram of mutual induction of GSW1 breaker

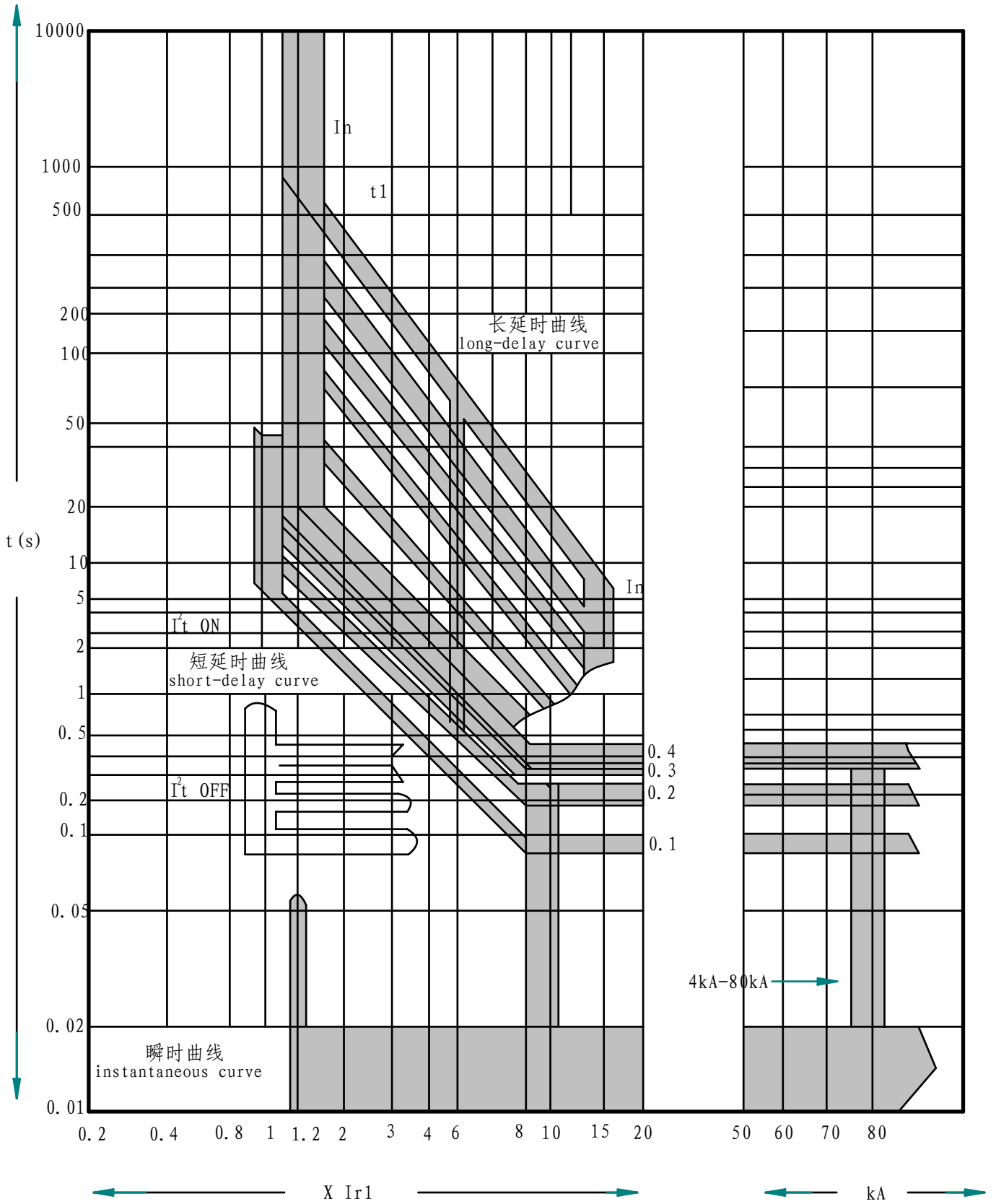

图 7
table 7

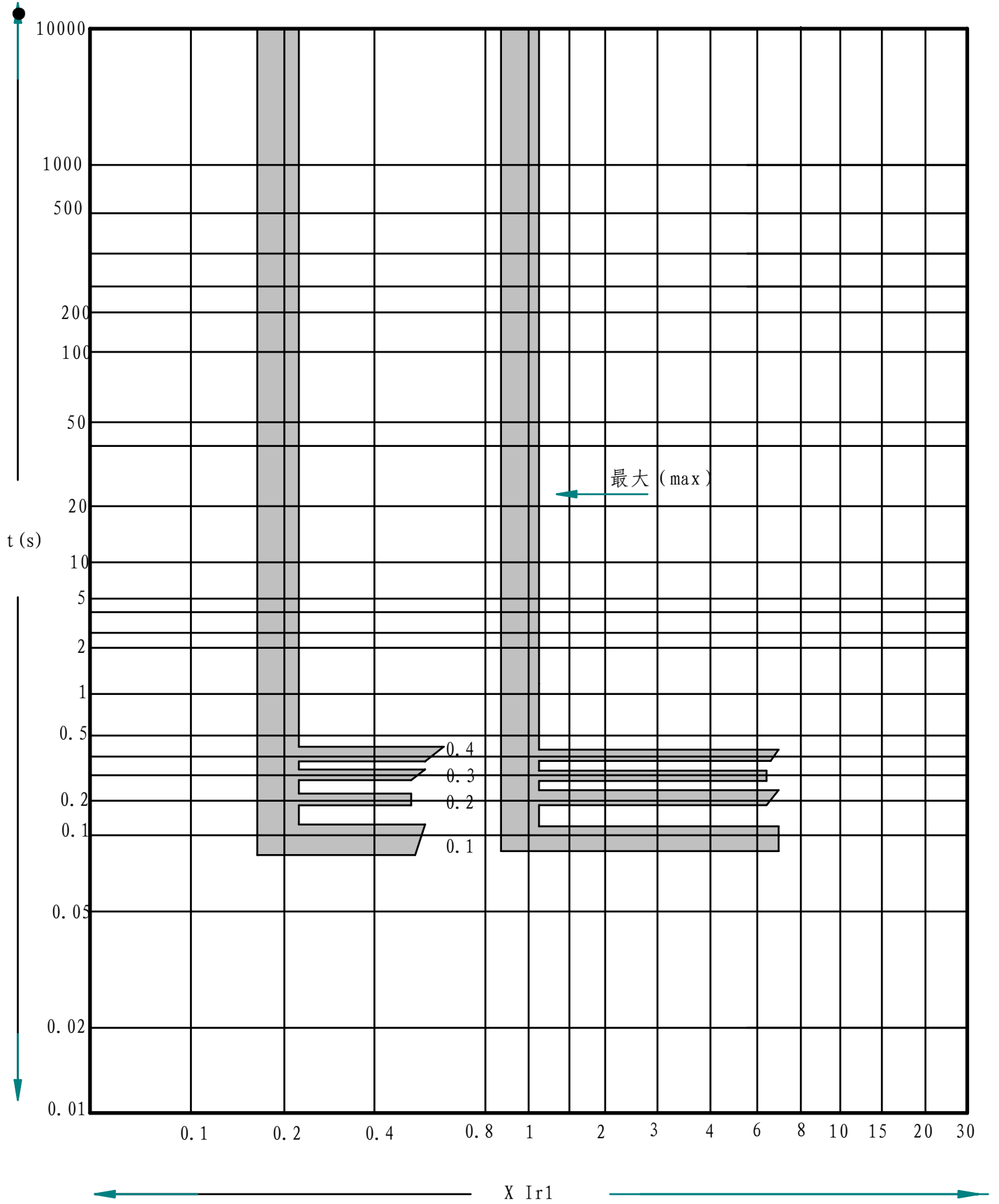

图 8
table 8

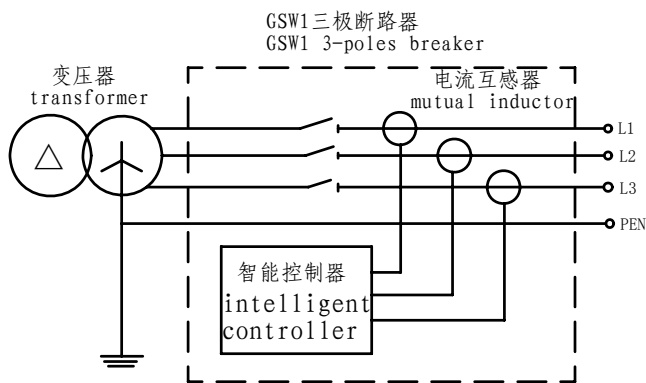

图 9
table 9

- TN-C、TN-C-S、TN-S配电系统中选用GSW1三极断路器。
- 接地故障保护信号取三相电流矢量。
- 保护特性为定时限保护。
- To select GSW1 3-poles breaker for TN-C, TN-C-S and TN-S distribution system.
- The earthed error protection signal from sum of vectors of triphase current.
- The protection feature is definite time.

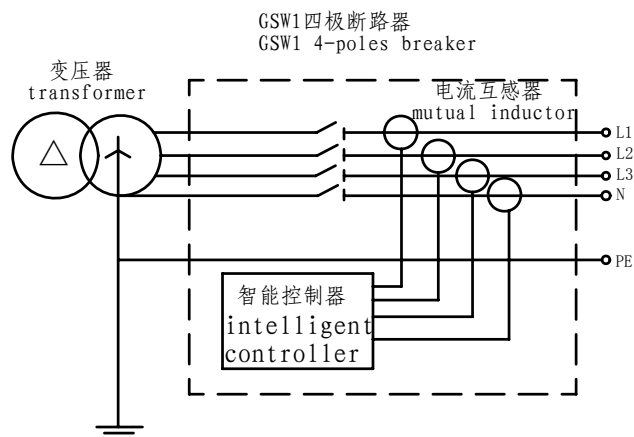
- TN-S配电系统中选用GSW1四极断路器。
- 接地故障保护取三相电流及N极电流的矢量。
- 保护特性为定时限保护。
- To select GSW1 4-poles breaker for TN-S distribution system.
- The earthed error protection signal from sum of vectors of triphase and N-phase current.
- The protection feature is definite time.

- TN-S配电系统中选用GSW1三极断路器。
- 外接中性线N电流互感器作为接地故障保护用，互感器安装地点距离断路器最大为2米。
- 接地故障保护信号取三相电流及N相电流的矢量。
- 保护特性为定时限保护。
- To select GSW1 3-poles breaker for TN-S distribution system.
- The mutual inductor, linking externally to N-phase, works for earthed error protection, the maximum distance from the place where the mutual inductor is mounted to breaker is 2 meters.
- The earthed error protection signal from sum of vectors of triphase and N-phase current.
- The protection feature is definite time

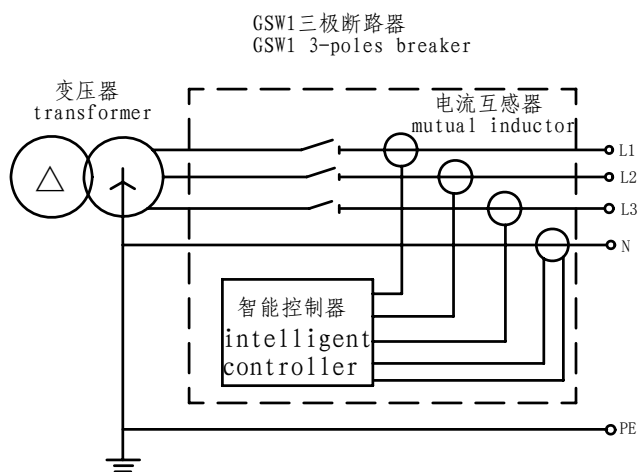
- 控制方式和运行模式见表6
- Control ways and operation mode see table 6

表 6
table 6

控制方式 Control ways	控制功能 Control function	适用场合 Applicability	运行模式 Operation mode
R型 Type R	常用 - 备用 间自投自复 Automatic transfer and restoration between normal and reserve power supply	电网和电网 Electric barbed wire and electric barbed wire	自动运行模式 Automatic operation mode
			常用电源运行模式 Normal power supply operation mode
			备用电源运行模式 Reserve power supply operation mode
			断/扣运行模式 Breaking/hook operation mode
S型 Type S	常用 - 备用间 自投不自复 Automatic transfer without restoration between normal and reserve power supply	电网和电网 Electric barbed wire and electric barbed wire	自动运行模式 Automatic operation mode
			常用电源运行模式 Normal power supply operation mode
			备用电源运行模式 Reserve power supply operation mode
			断/扣运行模式 Breaking/hook operation mode
F型 Type F	常用 - 发电电 源间自投自复 Automatic transfer and restoration between normal and generator supply	电网和发电机 Electric barbed wire and generator	自动运行模式 Automatic operation mode
			常用电源运行模式 Normal power supply operation mode
			备用电源运行模式 Reserve power supply operation mode
			断/扣运行模式 Breaking/hook operation mode

● R型、S型、F型的常用电源运行模式:

按下“常用电源”键，如常用电源已接通，系统不予另行操作，如备用电源已接通，系统强制备用电源断路器立即断开，常用电源断路器延时接通，如常用电源随后出现异常，常用电源将延时断开。

● R型、S型、F型的备用电源运行模式:

按下“备用电源”键，如备用电源已接通，系统不予另行操作，如常用电源已接通，系统强制常用电源断路器立即断开，备用电源断路器延时闭合，如备用电源随后出现异常，备用电源将延时断开。

● R型、S型、F型的断/扣运行模式:

按下“断/扣”键，无论哪一路电源供电常用、备用断路器都立即断开（如已闭合），停止向下一级供电。

● R型、S型、F型的脱扣:

当常用电源断路器或备用电源断路器因过载脱扣后，控制器脱扣信号灯亮，蜂鸣器鸣叫报警，此时液晶显示页面不显示故障，仅显示在运行页。当出现脱扣后，必须先查明脱扣原因并排除故障，然后按控制器的“断/扣”键，这时自动转换开关方可正常工作。

注1
Note 1

t1: 转换断开延时时间（6-999秒，用户可调，出厂时整定在6秒）

t1: Delay time before power supply switching off while switching operation(6-999S Adjusted by users, time is set one second before factory price)

t2: 转换接通延时时间（6-999秒，用户可调，出厂时整定在6秒）

t2: Delay time before power supply switching on while switching operation(6-999S Adjusted by users, time is set three second before factory price)

t3: 返回断开延时时间（6-999秒，用户可调，出厂时整定在6秒）

t3: Delay time before power supply switching off while restoring operation(6-999S Adjusted by users, time is set one second before factory price)

t4: 返回接通延时时间（6-999秒，用户可调，出厂时整定在6秒）

t4: Delay time before power supply switching on while restoring operation(6-999S Adjusted by users, time is set three second before factory price)

t5: 卸载延时时间（1-999秒，用户可调，出厂时整定在3秒）

t5: Delay time before giving out of the command of unload(1-999S Adjusted by users time is set three second before factory price)

t6: 发电延时时间（1-999秒，用户可调，出厂时整定在3秒）

t6: Delay time before giving out of the command of power generation (1-999S Adjusted by users, time is set three second before factory price)

● Normal power operating modes for type R, type S, type F:

Press "normal key", as normal power has connected, the system not operating separately, as reserve power has connected, the system immediately disconnect reserve breaker. normal breaker close after delay time, the normal power starts operating, if normal power appeared malfunction, reserve power will be disconnected after delay time.

● Reserve power operating modes for type R, type S, type F:

Press "reserve key", as reserve power has connected, the system not operating separately, as normal power has connected, the system immediately disconnect normal breaker. reserve breaker close after delay time, if reserve power appeared malfunction, reserve power will be disconnected after delay time.

● Open and hook modes for type R, type S, type F:

Press "open and hook key", operation of normal power or reserve power anyhow, normal breaker and reserve breaker immediately will disconnect (as has been closing), stop operation of lower power supply.

● Release of type R, type S, type F:

When normal breaker or reserve breaker overload release, release light is lit, the buzzer alarm calls, this LED display page of operation without fault page, when has release it must first identify the reasons and troubleshooting, then press "open/hook" key of controller, automaticall transfer switch can work properly.

- R型自动运行模式控制逻辑功能 (见表7)
- Control logic function of Automatic operation mode for type R (see table 7)

表7
table 7

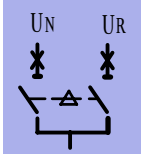
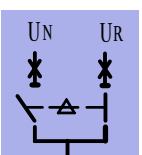
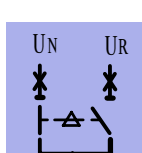
常用电源 (U _N) Normal power supply	备用电源 (U _R) Reserve power supply	工作状态 Working state	说明 Explanation
正常 Normal	正常 Normal		常用电源供电, 常用电源和备用电源信号灯稳定点亮。 Operation of the normal power supply, lights of normal power supply and reserve power supply lit stability.
异常 Anomaly	正常 Normal		常用电源切除, 动作时间t1, 常用电源信号灯闪烁报警。 Normal power supply will be switch off and the action time is t1, light of normal power supply flashing alarm.
异常 Anomaly	正常 Normal		备用电源投入供电, 动作时间t2, 常用电源信号灯闪烁报警。 Reserve power supply starts operation, the action time is t2, light of normal power supply flashing alarm.
恢复正常 Restores normal	正常 Normal		备用电源闭切除, 动作时间t3, 常用电源和备用电源的信号灯稳定点亮。 Reserve power supply will be switch off and the action time is t3, lights of normal power supply and reserve power supply lit stability.
恢复正常 Restores normal	正常 Normal		常用电源投入供电, 动作时间t4, 常用电源和备用电源的信号灯稳定点亮。 Normal power supply starts operation, the action time is t4, lights of normal power supply and reserve power supply lit stability.

● S型自动运行模式控制逻辑功能(见表8)

● Control logic function of Automatic operation mode for type S (see table 8)

表8
table 8

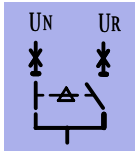
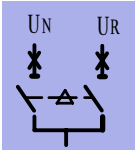
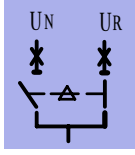
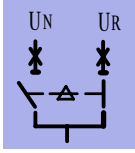
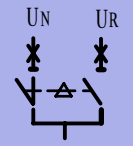
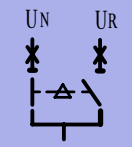
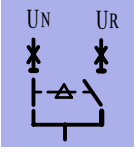
常用电源 (U _N) Normal power supply	备用电源 (U _R) Reserve power supply	工作状态 Working state	说明 Explanation
正常 Normal	正常 Normal		常用电源供电, 常用电源和备用电源信号灯稳定点亮。 Operation of the normal power supply, lights of normal power supply and reserve power supply lit stability.
异常 Anomaly	正常 Normal		常用电源切除, 动作时间t1, 常用电源信号灯闪烁报警。 Normal power supply will be switch off and the action time is t1, light of normal power supply flashing alarm.
异常 Anomaly	正常 Normal		备用电源投入供电, 动作时间t2, 常用电源信号灯闪烁报警。 Reserve power supply starts operation, the action time is t2, light of normal power supply flashing alarm.
恢复正常 Restores normal	正常 Normal		备用电源继续供电, 常用电源和备用电源的信号灯稳定点亮。 Reserve power supply still working, light of normal power supply and reserve power supply lit stability.
正常 Normal	异常 Anomaly		备用电源切除, 动作时间t3, 常用电源的信号灯稳定点亮, 备用电源的信号灯闪烁报警。 Reserve power supply switching off, the action time is t3, light of normal power supply lit stability, light of reserve power supply flashing alarm.
正常 Normal	异常 Anomaly		常用电源供电, 动作时间t4, 常用电源的信号灯稳定点亮, 备用电源的信号灯闪烁报警。 Normal power supply starts operating, the action time is t4, light of normal power supply lit stability. light of reserve power supply flashing alarm.
正常 Normal	正常 Normal		常用电源继续供电, 常用电源和备用电源的信号灯稳定点亮。 Normal power supply still working, light of normal power supply and reserve power supply lit stability.

- F型自动运行模式控制逻辑功能(见表9)
- Control logic function of Automatic operation mode for type F (see table 9)

表9 table 9

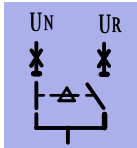
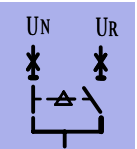
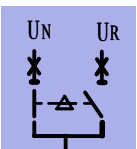
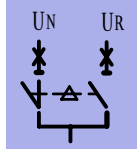
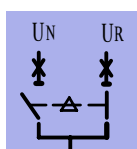
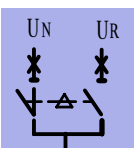
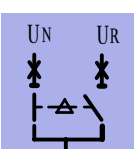
常用电源 (U _N) Normal power supply	发电电源 (U _R) The generating power supply	工作状态 Working state	说明 Explanation
正常 Normal	未发电 Not generation		常用电源供电, 常用电源信号灯稳定点亮。 Operation of the normal power supply, lights of normal power supply lit stability.
异常 Anomaly	未发电 Not generation		常用电源继续供电, 发电机启动信号发出, 动作时间t6, 常用电源信号灯闪烁报警。 Normal power supply still work, The command to start the generator is given out, the action time is t6, light of normal power supply flashing alarm.
异常 Anomaly	发电正常 Generation Normal		常用电源继续供电, 卸载信号发出, 动作时间t5, 常用电源信号灯闪烁报警。 Normal power supply still work, the action time is t5, light of normal power supply flashing alarm.
异常 Anomaly	正常 Normal		常用电源切除, 动作时间t1, 发电电源的信号灯稳定点亮, 常用电源信号灯闪烁报警。 The normal power supply is switched off, the action time is t1, light of the generating power supply lit stability. light of normal power supply flashing alarm.
异常 Anomaly	正常 Normal		发电电源供电, 动作时间t2, 发电电源的信号灯稳定点亮, 常用电源信号灯闪烁报警。 The generating power supply starts operating, the action time is t2, light of the generating power supply lit stability. light of normal power supply flashing alarm.
恢复正常 Restores normal	正常 Normal		发电机电源切除, 动作时间t3, 再延时t5后, 恢复所卸负载, 常用电源的信号灯稳定点亮。 The generating power supply is switch off, the action time is t3, after delay t5, recovery dumping load, the normal power supply lit stability.
正常 Normal	发电机停机 The generating stop running		常用电源供电, 动作延时t4, 常用电源的信号灯稳定点亮, 再延时3分钟后, 发电机停机信号发出, 发电机停机。 Normal power supply starts operating, the action time is t4, lights of normal power supply lit stability. after delay 3 min, the command to stop the generation is give out, the generation stop running.

GSA1控制器采用液晶显示方式。通过“换页”键切换显示页面，每一页为一不同功能页面，由键盘和显示屏实现人机对话，操作简单，结构清晰。

GSA1 LCD controller display pages through an exchange of page ,each page features a different function pages ,from the keyboard and csreen to achieve human-machine dialogue ,simple and clear structure.

- 控制器的符号介绍(见表10)
- sign introduced of controller see table 1

表10
table 10

序号 Order	符号 Sign	意义 Meaning
1	U _i	额定绝缘电压 Rated insulation voltage
2	U _n	额定工作电压 Rated working voltage
3	I _n	额定工作电流 Rated working current
4	N	常用电源 Normal power supply
5	R	备用电源 Reserve power supply
6	U ₁₁ , U ₁₂ , U ₁₃	常用电源A相、B相、C相相电压值 The phase voltage value of A phase ,B phase , C phase of normal power supply
7	U ₂₁ , U ₂₂ , U ₂₃	备用电源A相、B相、C相相电压值 The phase voltage value of A phase ,B phase , C phase of reserve power supply
8	U _H	过电压值 Over-voltage value
9	U _L	欠电压值 Under-voltage value
10	Q _X	缺相 Lost phase
11	S _Y	失压 Lacking voltage
12	G _Y	过压 Over-voltage
13	Q _Y	欠压 Under-voltage
14	t ₁ -t ₆	见12页注1 See page 12 and note 1

● 铭牌页

液晶显示屏显示自动转换开关的铭牌参数，包括额定绝缘电压、额定工作电压、额定工作电流和产品型号。

说明:

标牌
 额定绝缘电压 额定工作电压
 额定工作电流
 产品型号

● Nameplate pages

LED screen display automatic switch plate and parameters, including rated insulation voltage, rated working voltage, rated working current and product type.

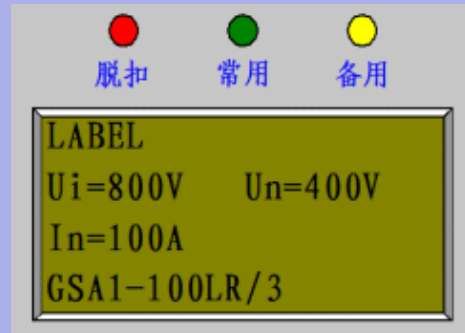

● 运行参数显示页面

在该页面显示两路电源的A相、B相、C相相电压参数。

说明:

运行
 常用电源A相相电压值 备用电源A相相电压值
 常用电源B相相电压值 备用电源B相相电压值
 常用电源C相相电压值 备用电源C相相电压值

● Run parameters pages

It will show phase voltage value of all phase of the two ways of power supply.

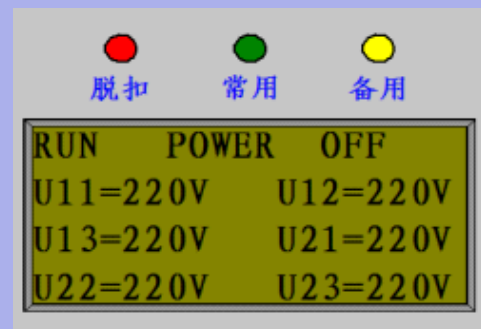

● 故障记忆显示页面:

可记忆上次从出现的故障电源(常用电源或备用电源)、故障类型(过压、欠压、缺相、失压)和故障电压的最高值和最低值。

说明:

故障显示 故障类型
 故障电源
 故障相
 故障相最低电压值 故障相最高电压值

● Error search page:

it can memory last power failure (normal power supply or reserve power supply), fault type (overvoltage, undervoltage, lost voltage, lacking phase), fault max voltage and min voltage .

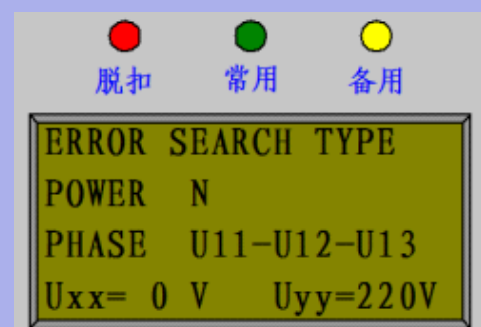

● 设定页

用“+”、“-”键改变密码值，使其密码（密码值均为“213”）相等后，即可进行其它项目设定。用“确认”键将光标移到对应的项目上，然后用“+”或“-”键改变其值，完成设定后，按下“确认”键即可。设定完成后返回到运行页面。如不进行任何操作，一分钟后将自动返回到运行页面。

● setting page

Password value can be changed by “+” key and “-”, it will can set other projects after password value (password value is 213) equivalent setting value, use “confirm” key and move the cursor to the corresponding project, and then use “+” and “-” keys to change its value and complete setting, then press the “confirm” key, perss returning key can return to running page. if don’t any operation, it will return to running page after a minute.

说明:

设定 密码	***
欠电压设定值	
过电压设定值	
转换断开延时	转换接通延时
返回断开延时	返回接通延时
卸载延时	发电延时

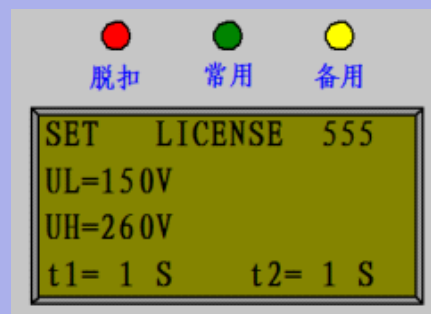

● 编程功能页

在该页面内可以对一些功能进行选择编程。

● Function programming page

The pages can used for function programming choices.

说明:

功能页	密码 ***
控制器类型	蜂鸣器
常用电源	设计员测试专用，用户不能修改
备用电源	设计员测试专用，用户不能修改



● 试验页

该页为产品设计员测试专用，用户无法进行操作。

● Test page

The page for product designer for test, users will not be able to operate.

说明:

测试功能	
常用电源	设计员测试专用，用户不能修改
备用电源	设计员测试专用，用户不能修改

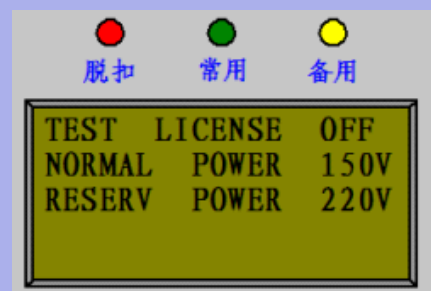

- GSA1-3M控制器面板 (见图10)
- Panel of GSA1 controller (see figure 10)

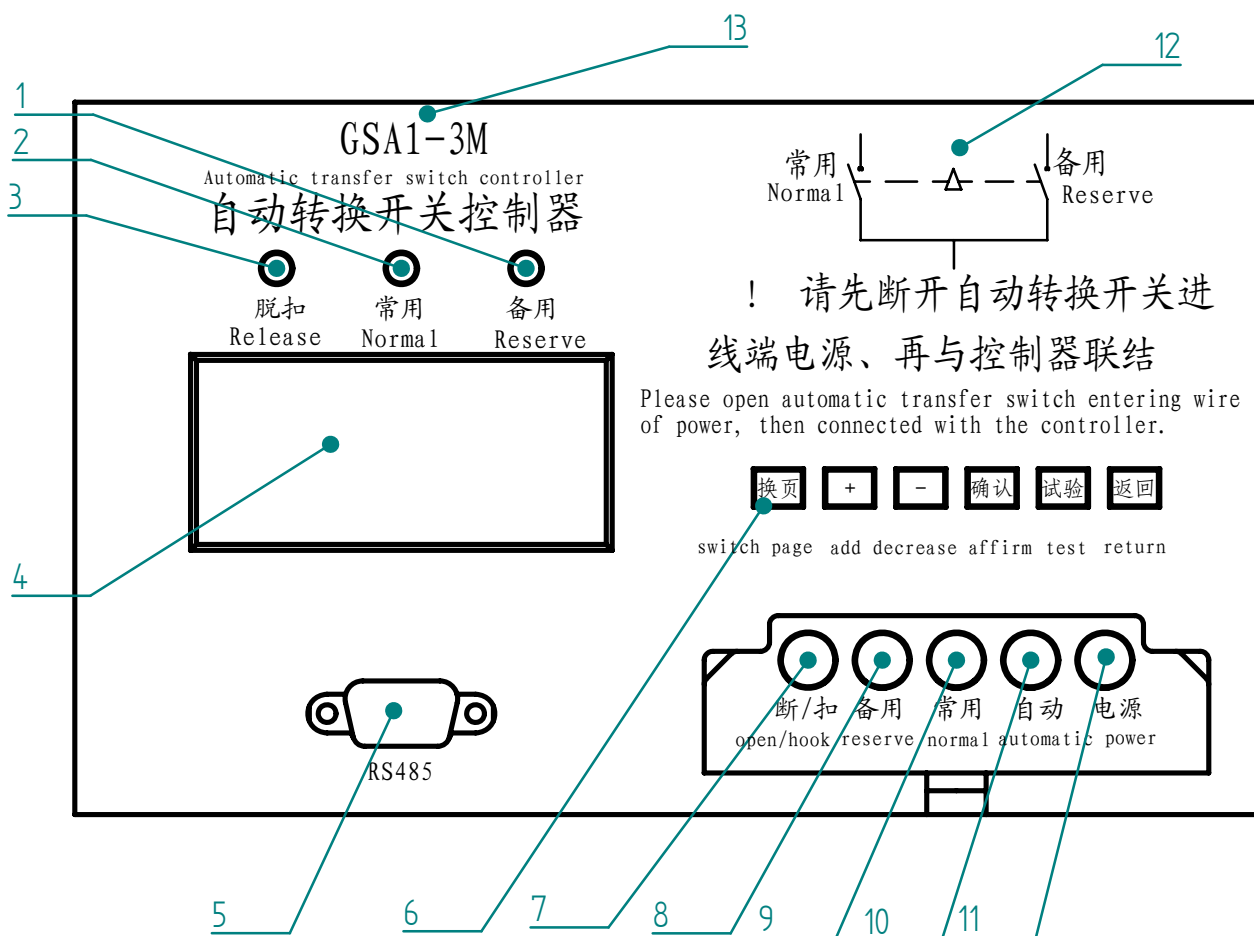

- | | | |
|--|--|---|
| 1. 备用电源信号灯
Reserve power signal light | 7. 断/扣运行按键
Open/hook keys | 13. 自动转换开关型号
Automatic transfer switch |
| 2. 常用电源信号灯
Normal power signal light | 8. 备用电源运行按键
Reserve power operation keys | |
| 3. 脱扣信号灯
Release signal light | 9. 常用电源运行按键
Normal power operation keys | |
| 4. 液晶显示屏
LED screen | 10. 自动运行按键
Automatic operation keys | |
| 5. 通信接口
Communicative interface | 11. 控制器电源按键
Controller power keys | |
| 6. 功能键
Function keys | 12. 自动转换开关标识
Identification of automatic switch | |

图 10
figure 10

- 控制器外形及安装尺寸见图11
- Controller Outline and mounting dimensions see figure 11



图 11
figure 11

机械软连锁水平安装示意图 (图12)

Mechanical linkage horizontal installation diagram (figure12)

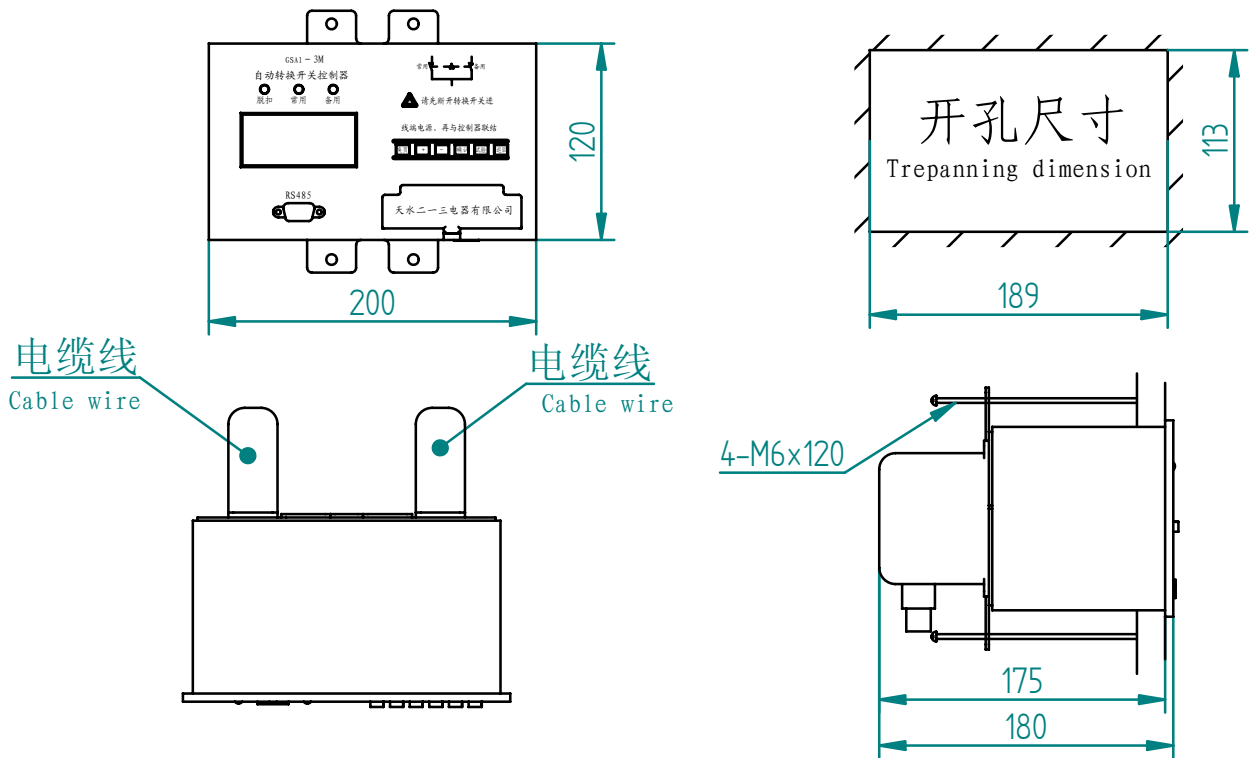
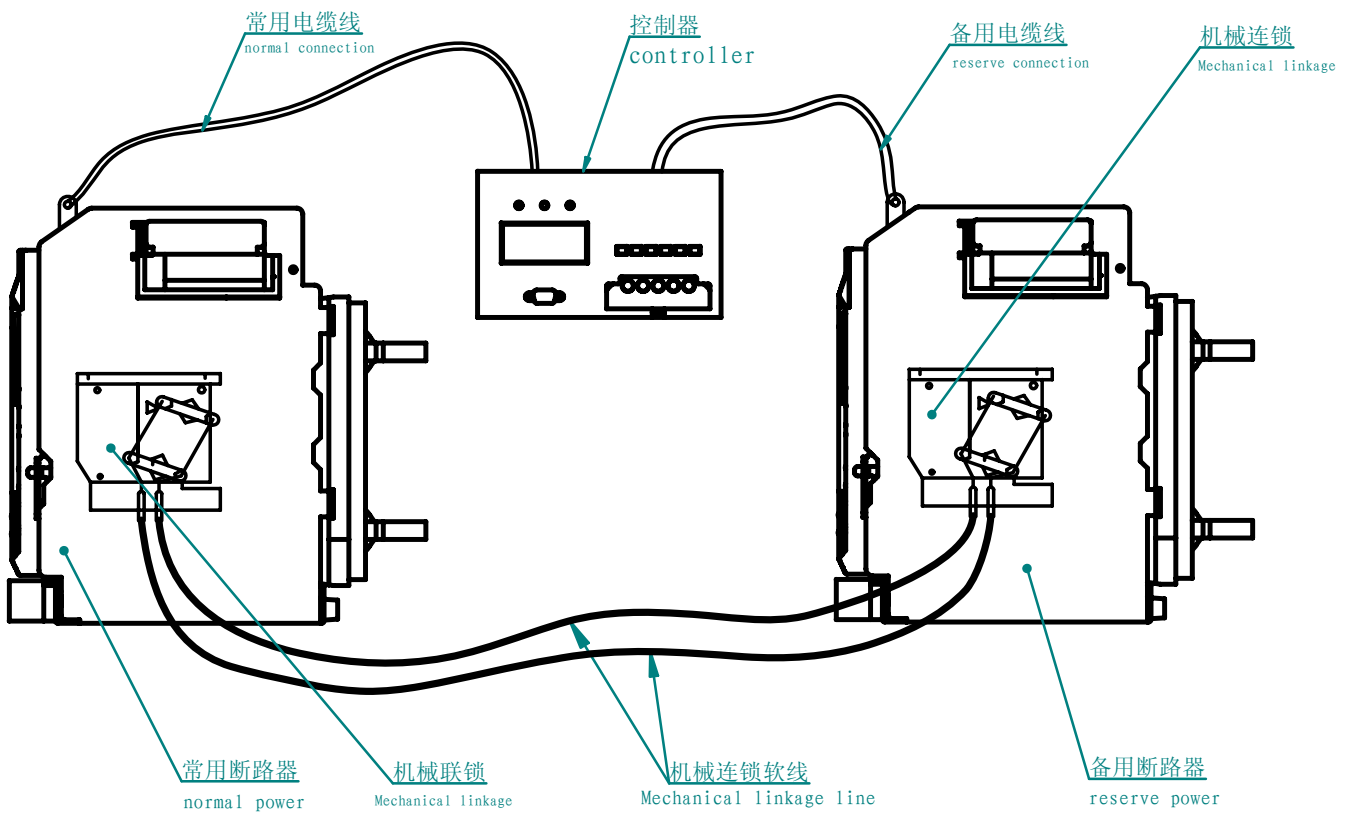
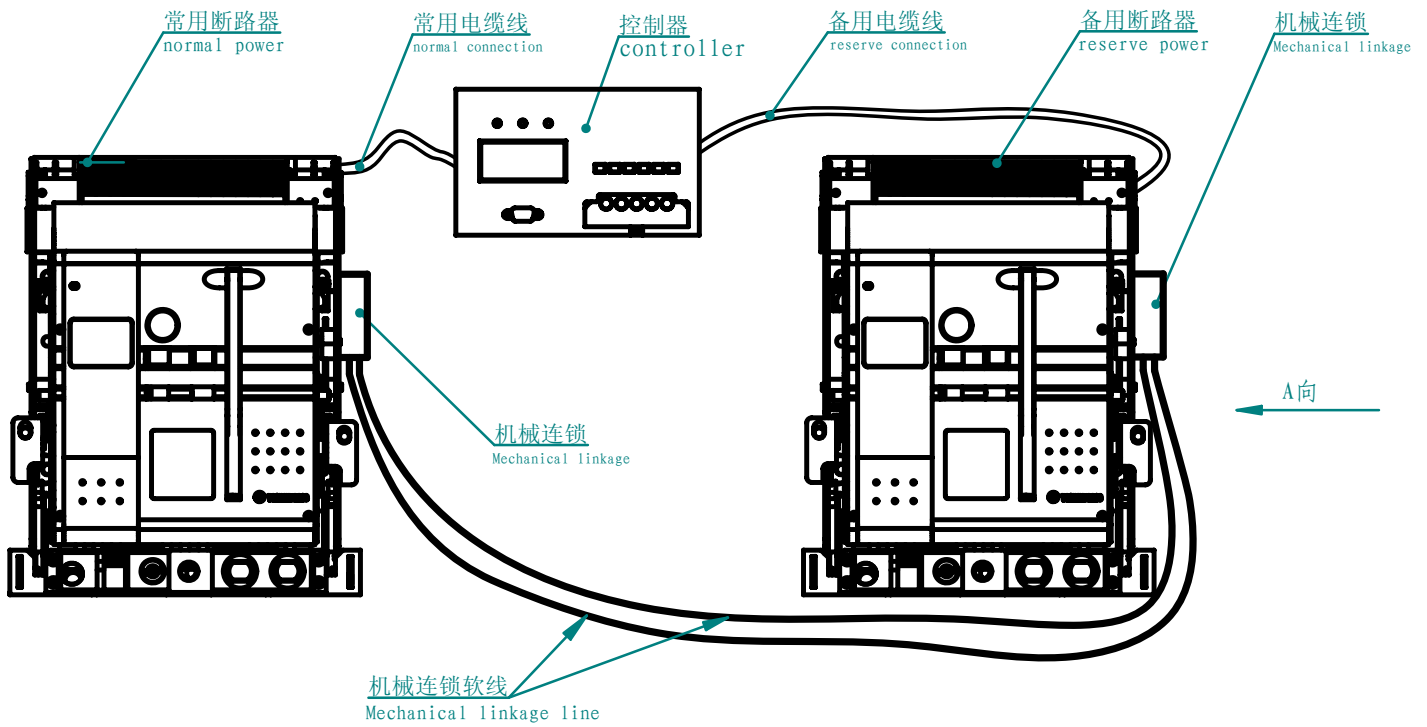

A向视图 (备用断路器向后平移后效果图)

图 12
figure 12

机械软连锁垂直安装示意图 (图13)

Mechanical interlocking vertical installation diagram (figure13)



图 13
figure 13

- GSW1机械连锁开孔尺寸 (图14)
- Mechanical interlock hole size (figure14)

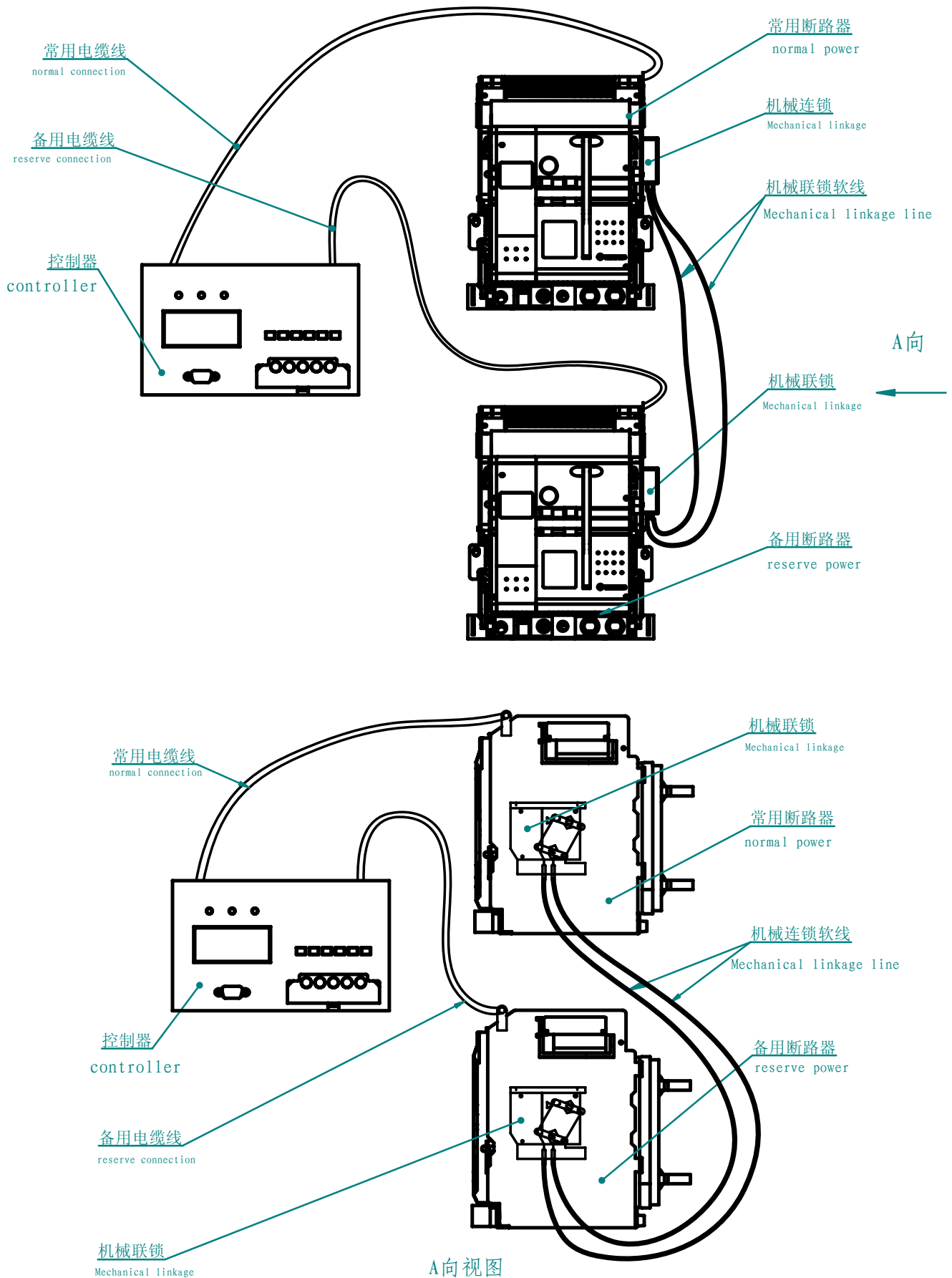
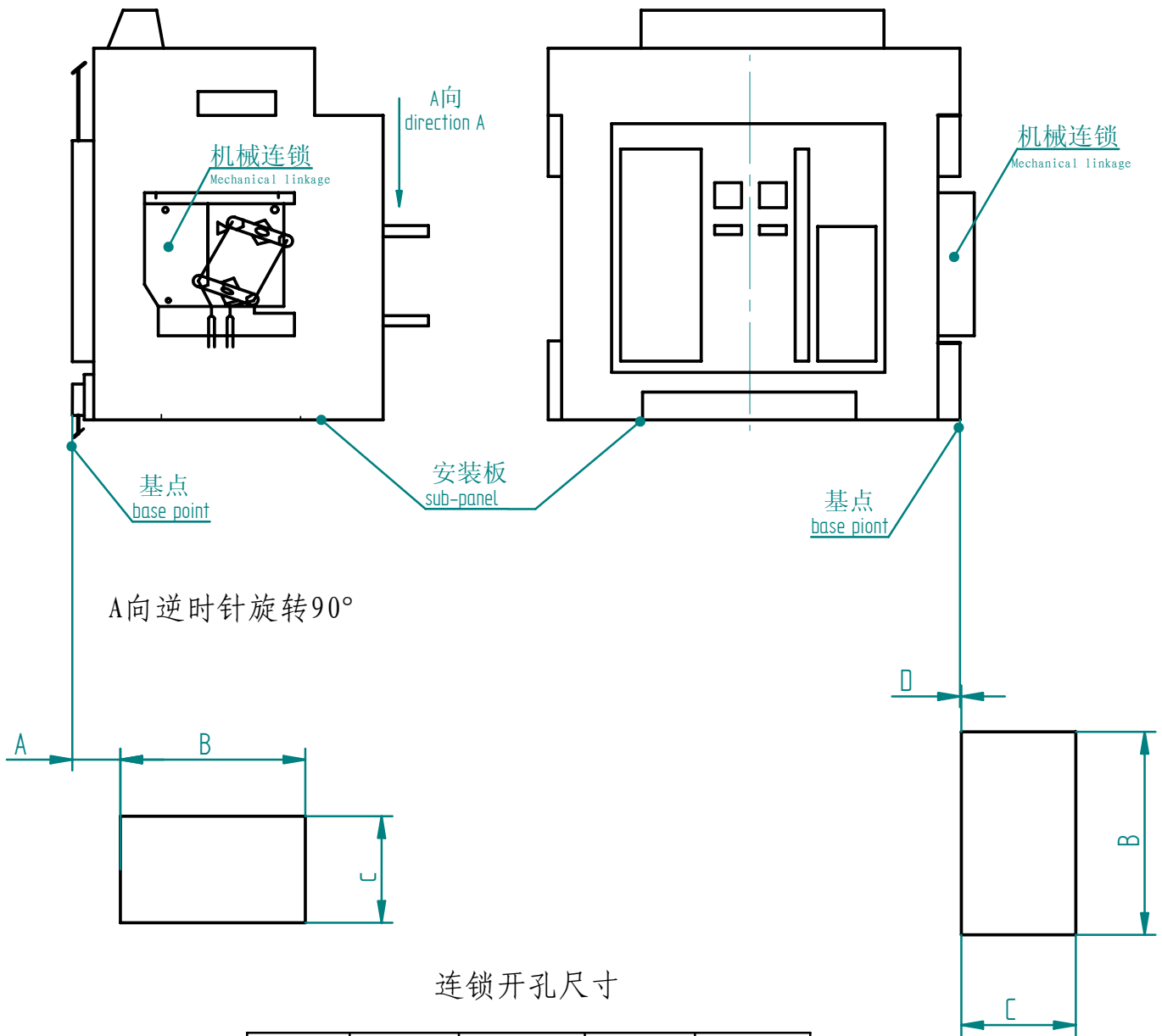

连锁开孔尺寸

壳架等级 (A)	a (mm)	b (mm)	c (mm)	d (mm)
1600	50	120	70	0
2000、 3200、 4000、 6300	50	180	70	0

图 14
figure 14

- GSW1-1600/3 抽屉式断路器外形尺寸、安装尺寸见图15
- Mounting dimensions and Outline dimensions of GSW1-1600/3 breaker (draw-out) see figure 15



图 15
figure 15

- GSW1-1600/3 固定式断路器外形尺寸、安装尺寸见图16
- Mounting dimensions and Outline dimensions of GSW1-1600/3 breaker (fixed 16)

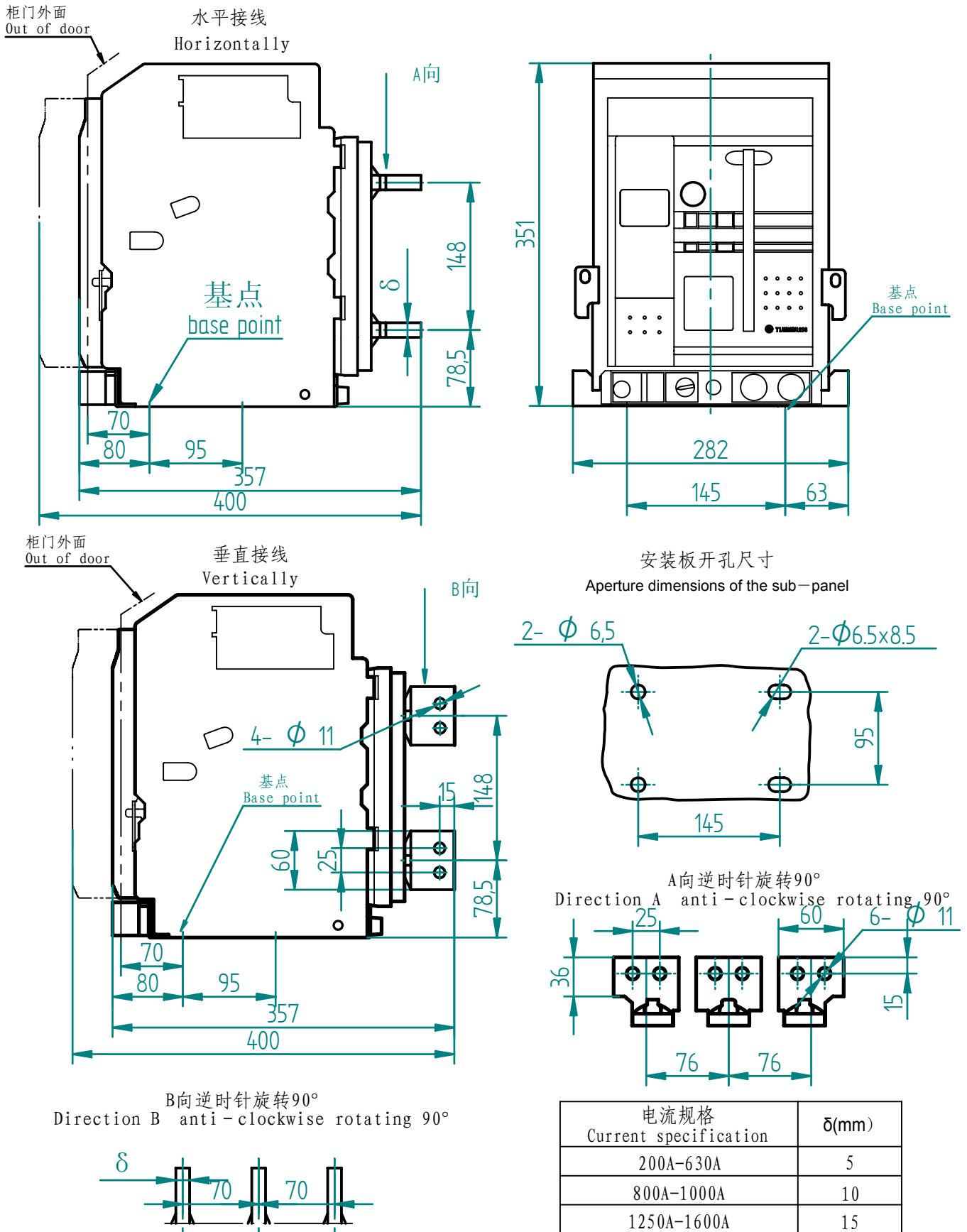
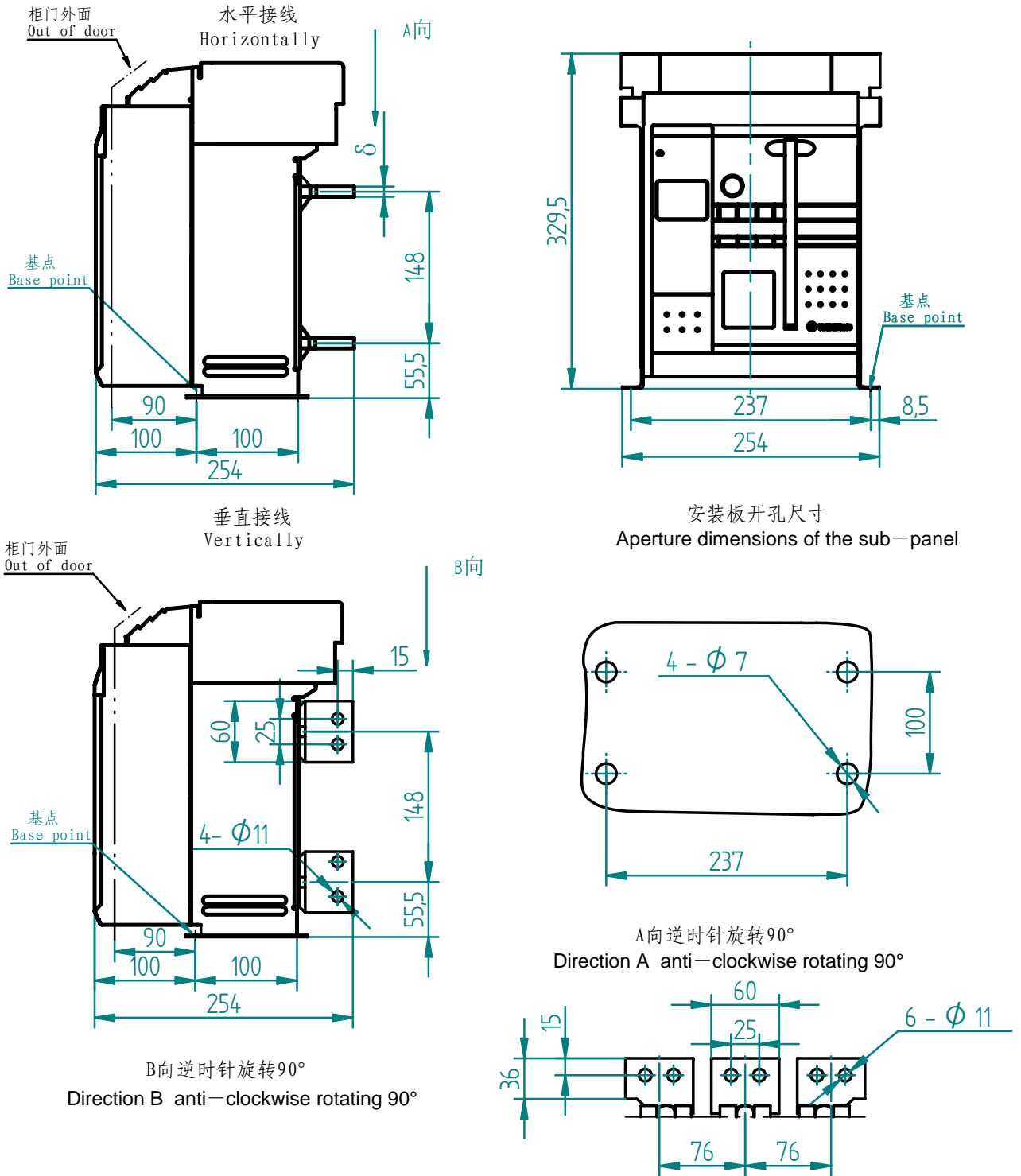

电流规格 current specification	δ (mm)
200A-630A	5
800A-1000A	10
1250A-1600A	15

图 16
figure 16

- GSW1-1600/3P+N 抽屉式断路器外形尺寸、安装尺寸 (图17)
- Mounting dimensions and Outline dimensions of GSW1-1600/3P+N breaker (draw-out)

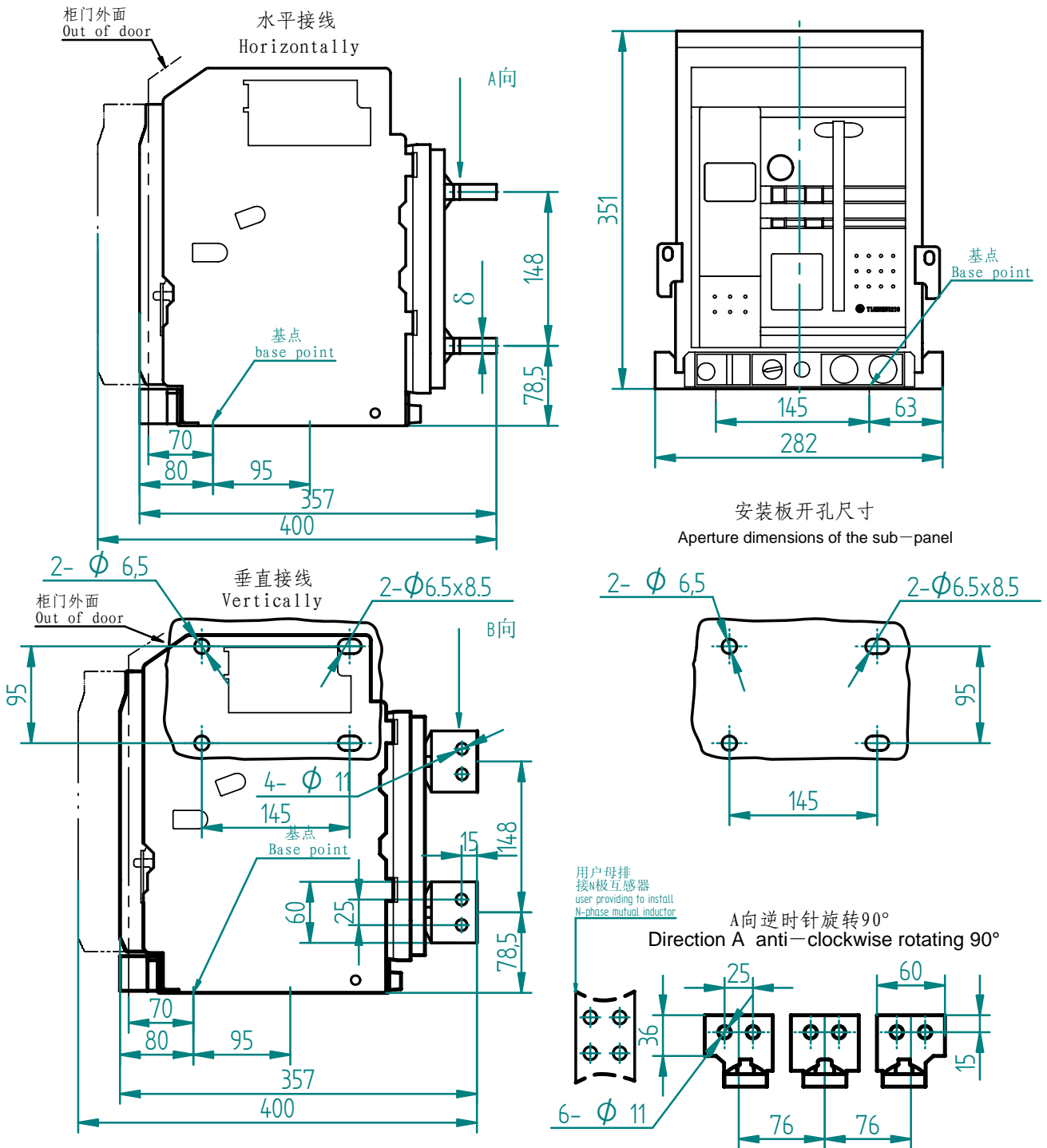

电流规格 current specification	δ (mm)
200A-630A	5
800A-1000A	10
1250A-1600A	15

图 17
figure 17

- GSW1-1600/3P+N 固定式断路器外形尺寸、安装尺寸 (图18)
- Mounting dimensions and Outline dimensions of GSW1-1600/3P+N breaker (fixed)

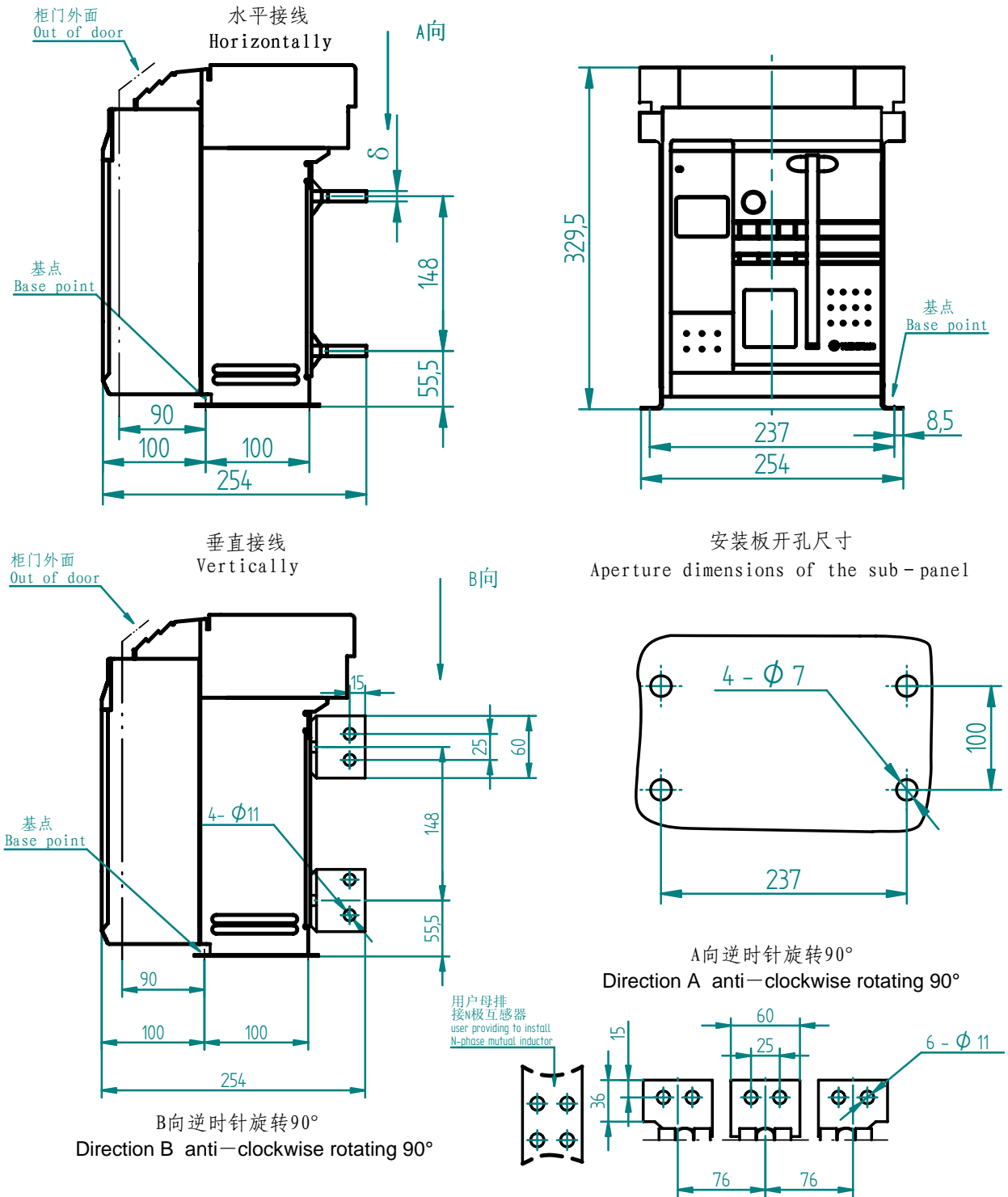

电流规格 current specification	δ (mm)
200A-630A	5
800A-1000A	10
1250A-1600A	15

图 18
figure 18

- GSW1-1600/4 抽屉式断路器外形尺寸、安装尺寸见图19
- Mounting dimensions and Outline dimensions of GSW1-1600/4 breaker (draw-out)

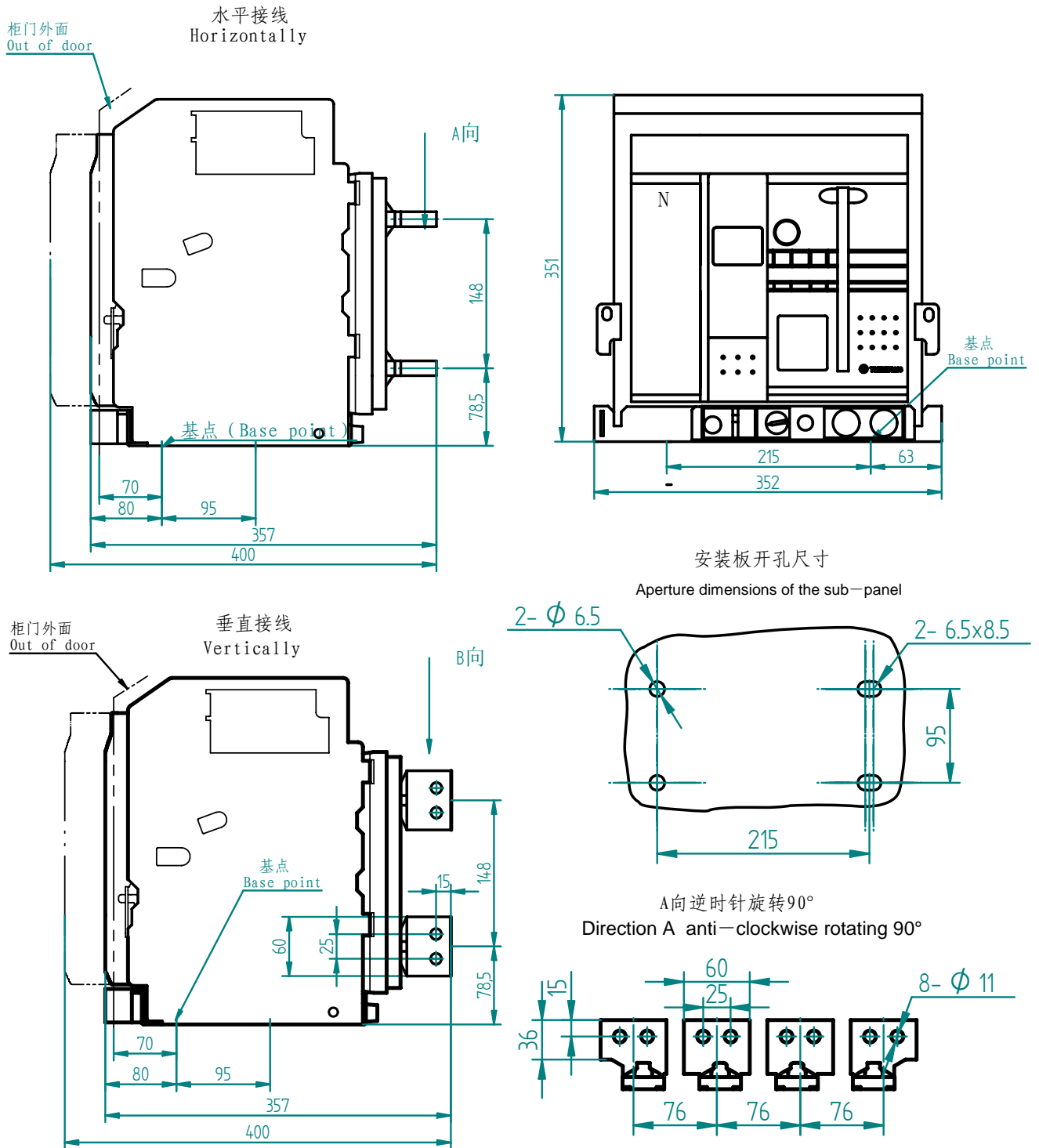

电流规格 current specification	δ (mm)
200A-630A	5
800A-1000A	10
1250A-1600A	15

图 19
figure 19

- GSW1-1600/4 固定式断路器外形尺寸、安装尺寸图20
- Mounting dimensions and Outline dimensions of GSW1-1600/4 breaker (fixed)

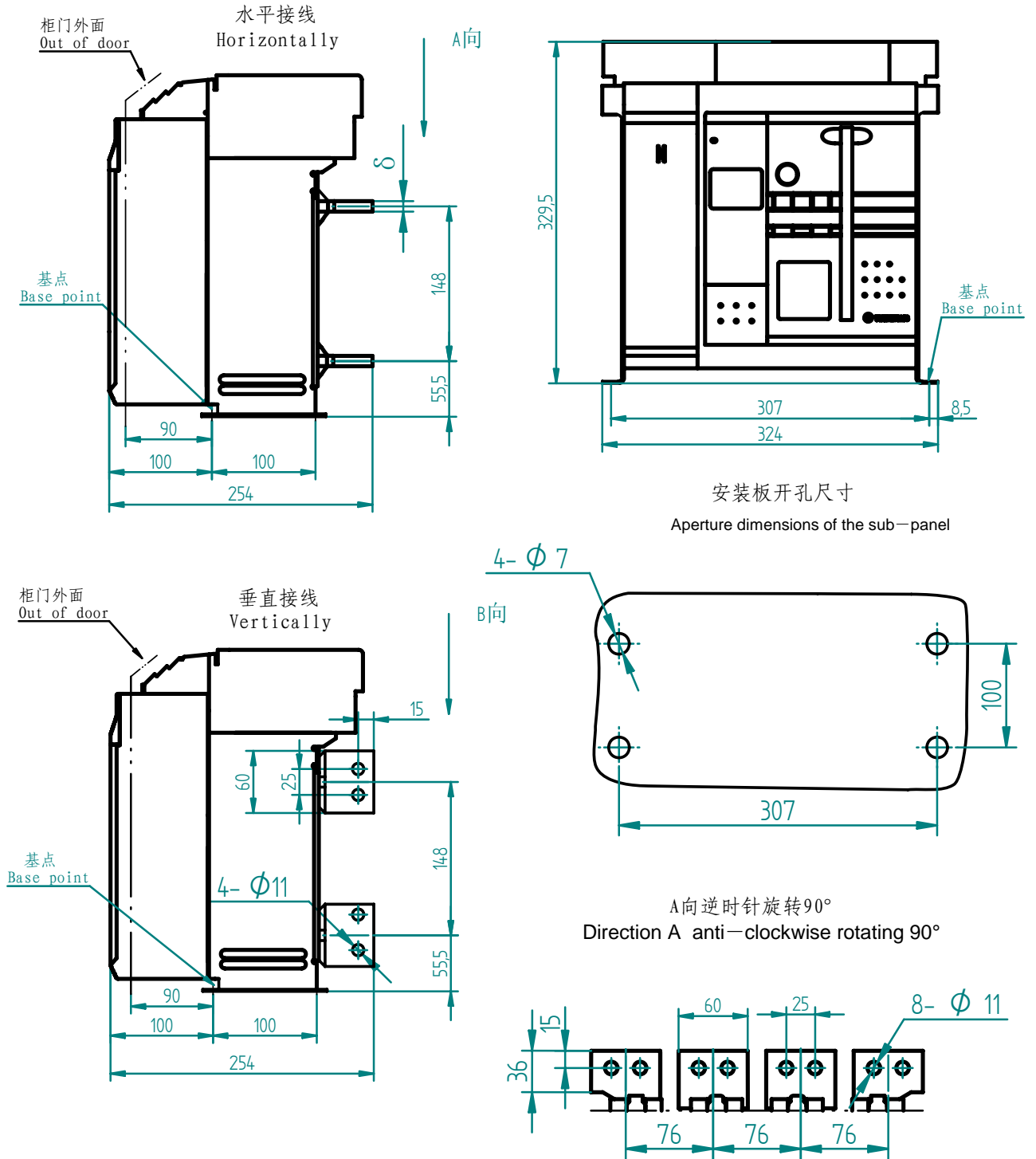

电流规格 current specification	δ (mm)
200A-630A	5
800A-1000A	10
1250A-1600A	15

图 20
figure 20

- GSW1-2000/3 抽屉式断路器外形尺寸、安装尺寸见图21
- Mounting dimensions and Outline dimensions of GSW1-2000/3 breaker (draw-out) see figure 21



图 21
figure 21

- GSW1-2000/3 固定式断路器外形尺寸、安装尺寸见图22
- Mounting dimensions and Outline dimensions of GSW1-2000/3 breaker (fixed) see figure 22

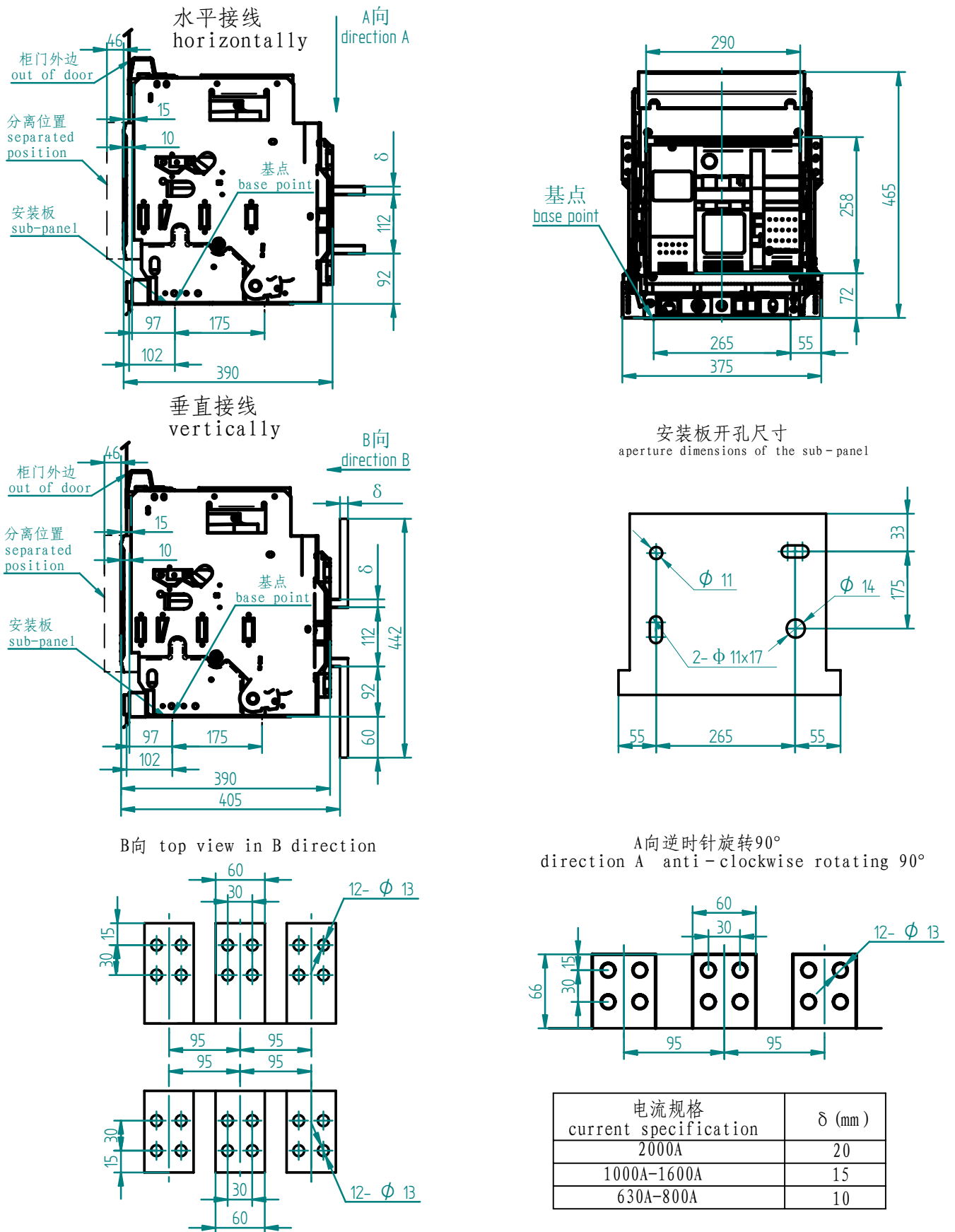

图 22
figure 22

外形及安装尺寸

OUTLINE AND MOUNTING DIMENSIONS

- GSW1-2000/3P+N 抽屉式断路器外形尺寸、安装尺寸见图23
- Mounting dimensions and Outline dimensions of GSW1-2000/3P+N breaker (draw-out) see figure 23

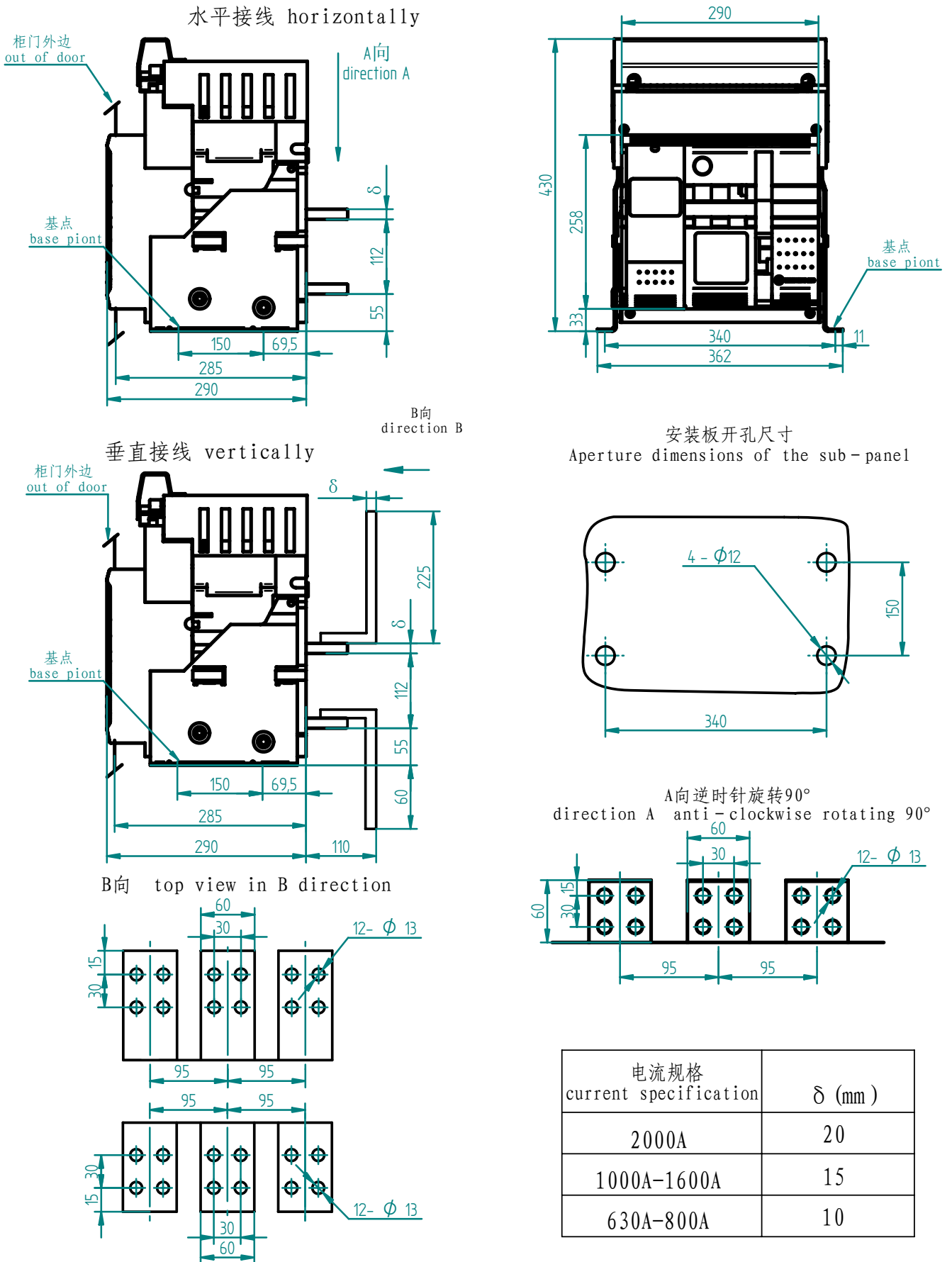
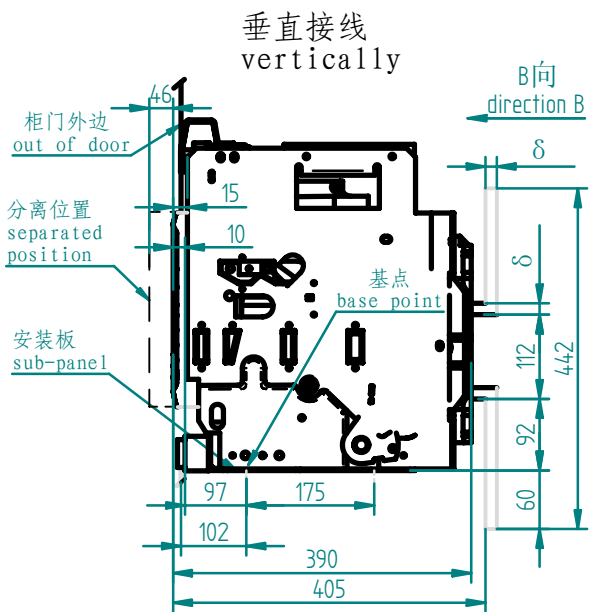
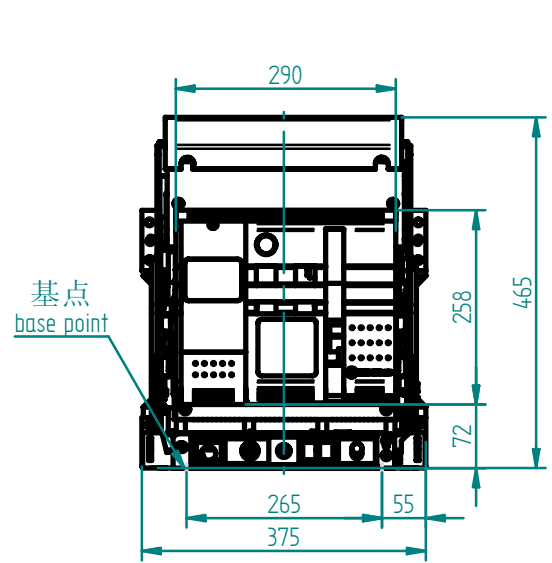
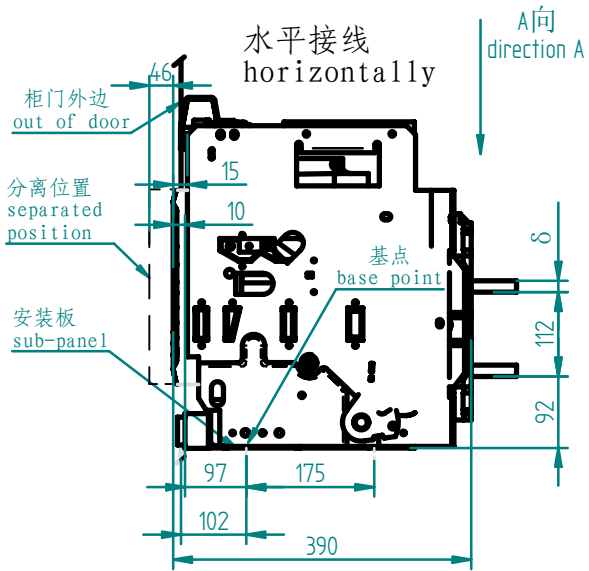

安装板开孔尺寸
aperture dimensions of the sub-panel

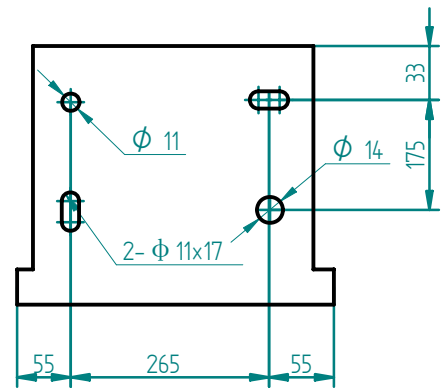

A向逆时针旋转90°
direction A anti-clockwise rotating 90°

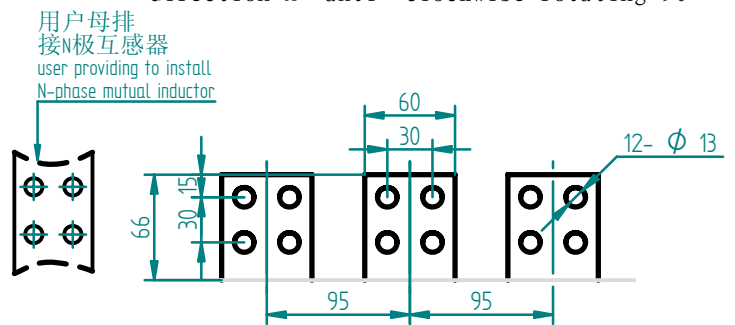
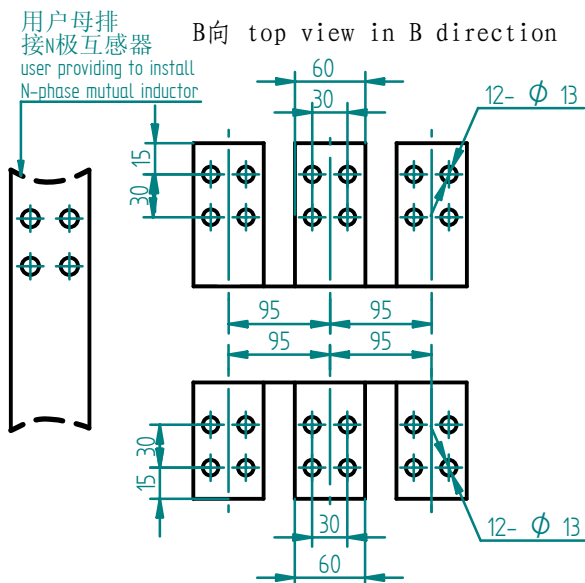

电流规格 current specification	δ (mm)
2000A	20
1000A-1600A	15
630A-800A	10

图 23
figure 23

外形及安装尺寸

OUTLINE AND MOUNTING DIMENSIONS

- GSW1-2000/3P+N 固定式断路器外形尺寸、安装尺寸见图24
- Mounting dimensions and Outline dimensions of GSW1-2000/3P+N breaker (fixed) see figure 24

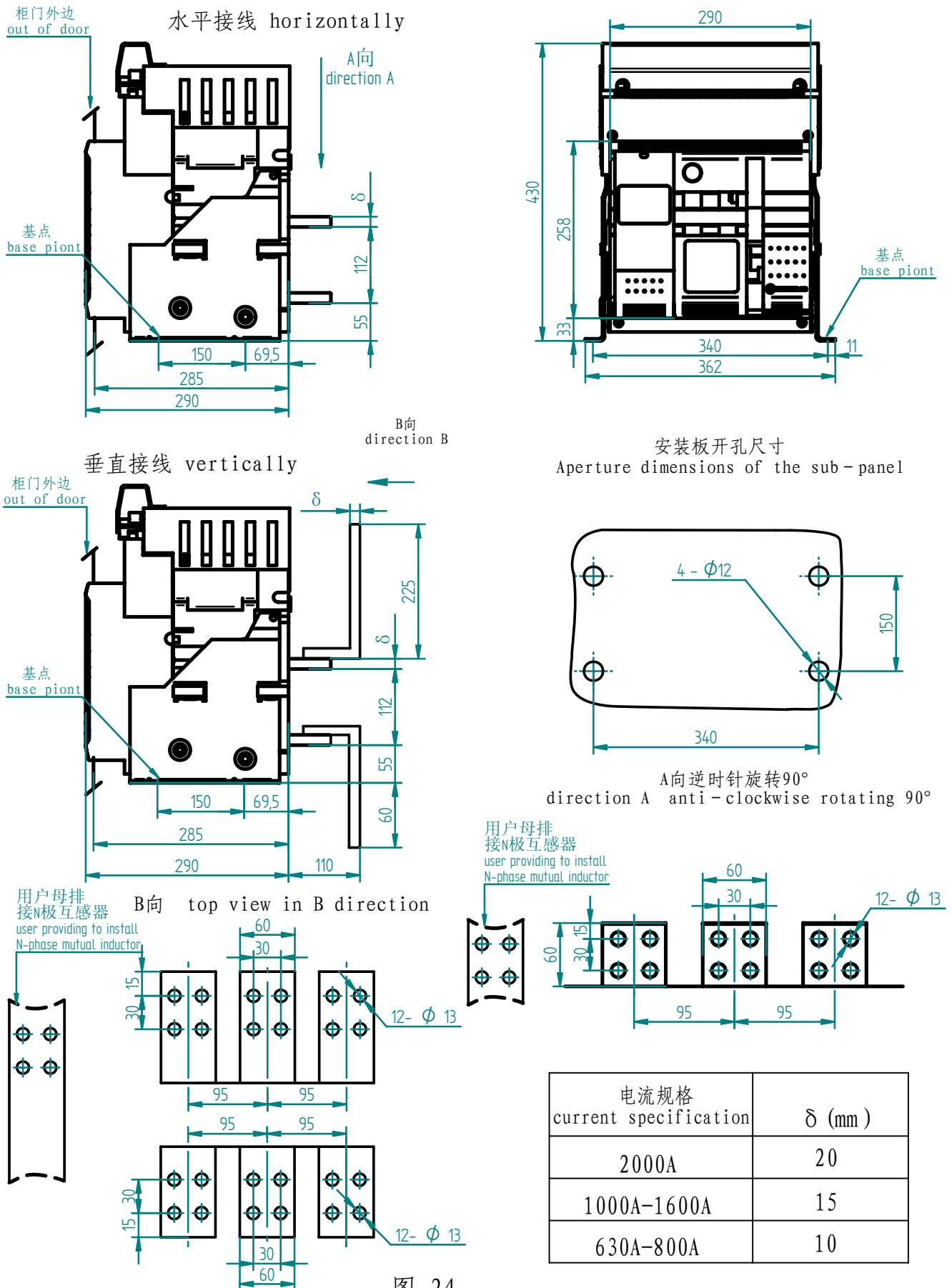

电流规格 current specification	δ (mm)
2000A	20
1000A-1600A	15
630A-800A	10

图 24
figure 24

- GSW1-2000/4 抽屉式断路器外形尺寸、安装尺寸见图25
- Mounting dimensions and Outline dimensions of GSW1-2000/4 breaker (draw-out) see figure 25



图 25
figure 25

- GSW1-2000/4 固定式断路器外形尺寸、安装尺寸见图26
- Mounting dimensions and Outline dimensions of GSW1-2000/4 breaker (fixed) see figure 26

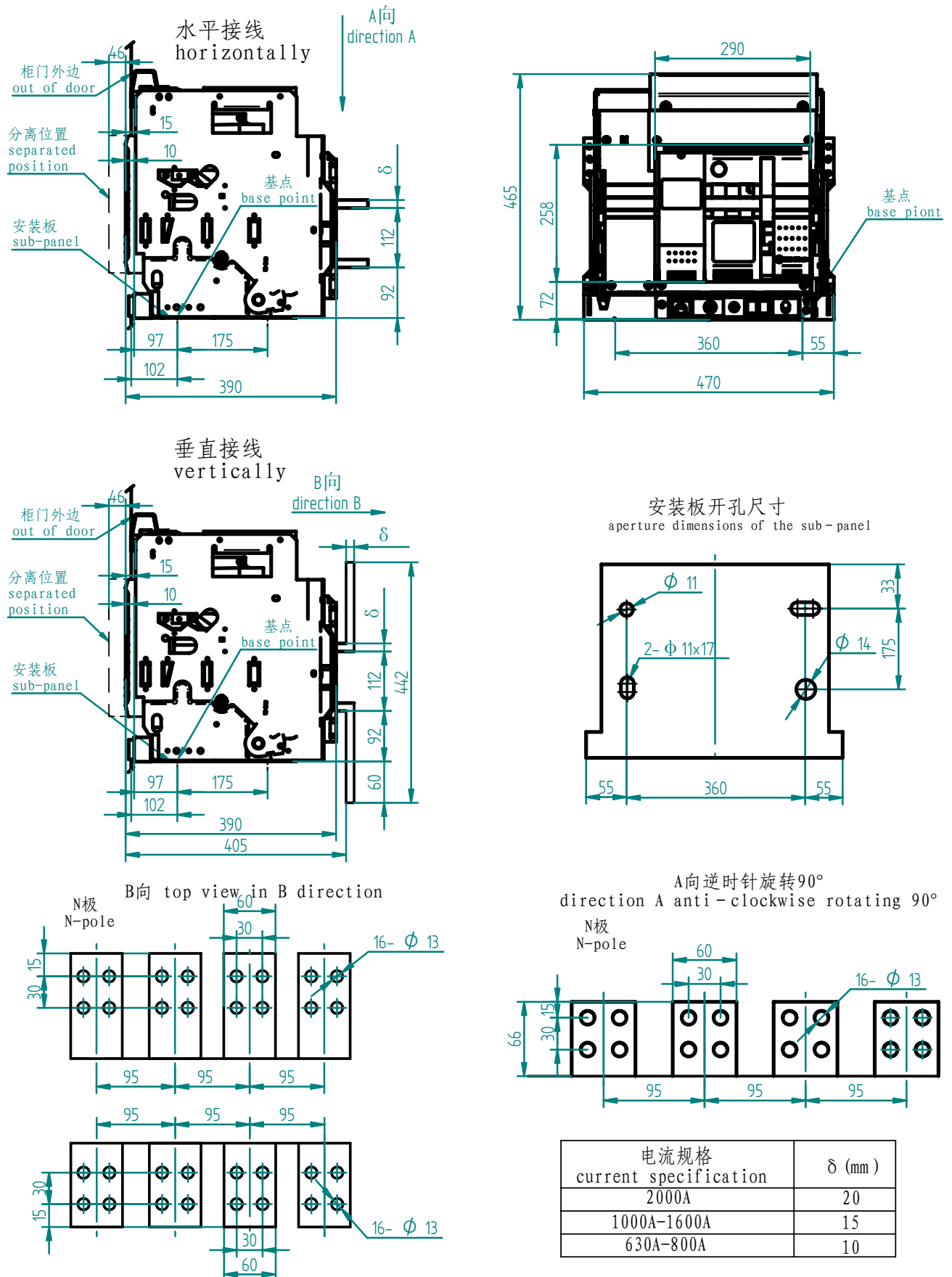

图 26
figure 26

- GSW1-3200/3 抽屉式断路器外形尺寸、安装尺寸见图27
- Mounting dimensions and Outline dimensions of GSW1-3200/3 breaker (draw-out) see figure 27

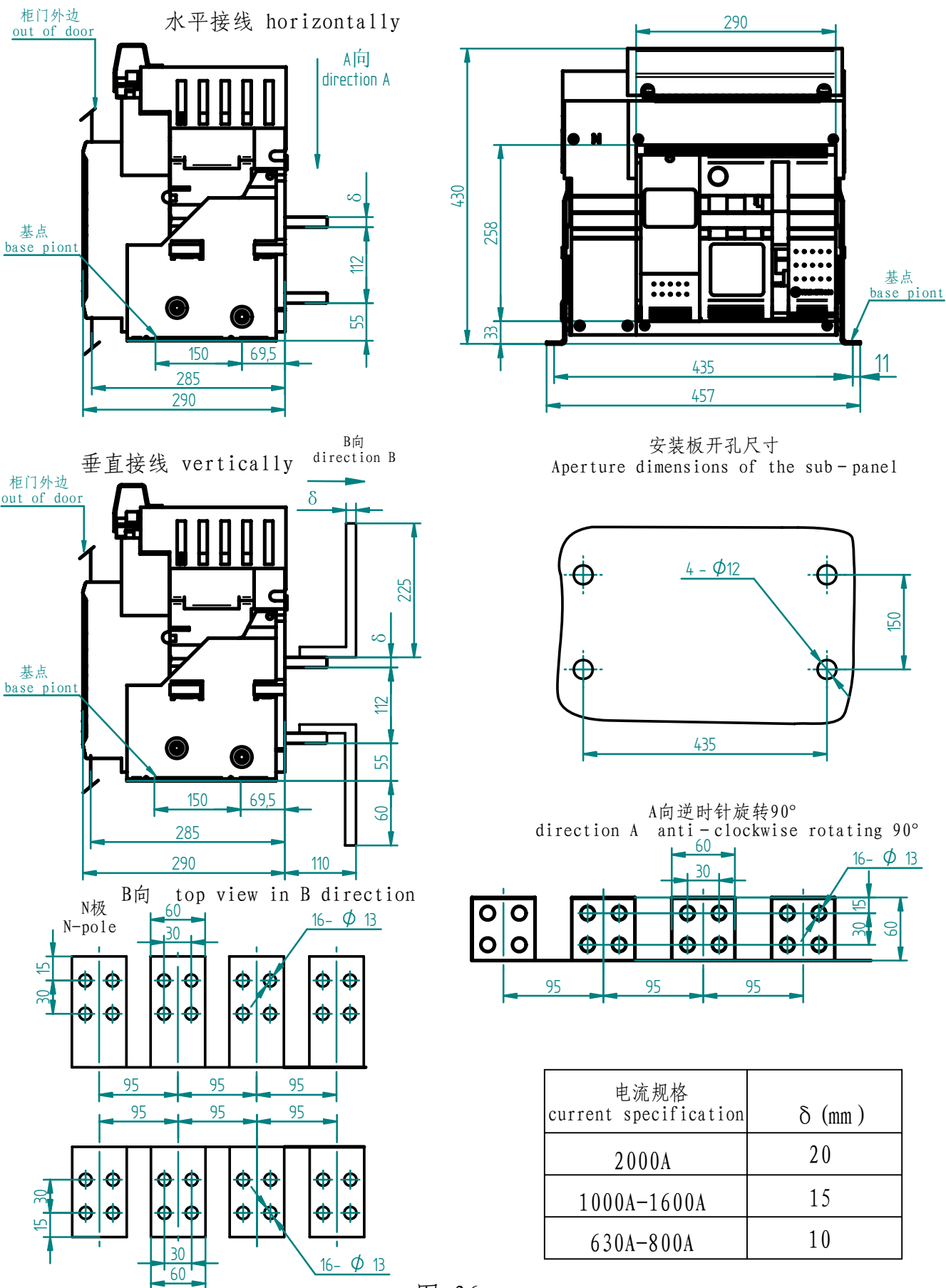

图27
figure 27

- GSW1-3200/3 固定式断路器外形尺寸、安装尺寸见图28
- Mounting dimensions and Outline dimensions of GSW1-3200/3 breaker (fixed) see figure 28

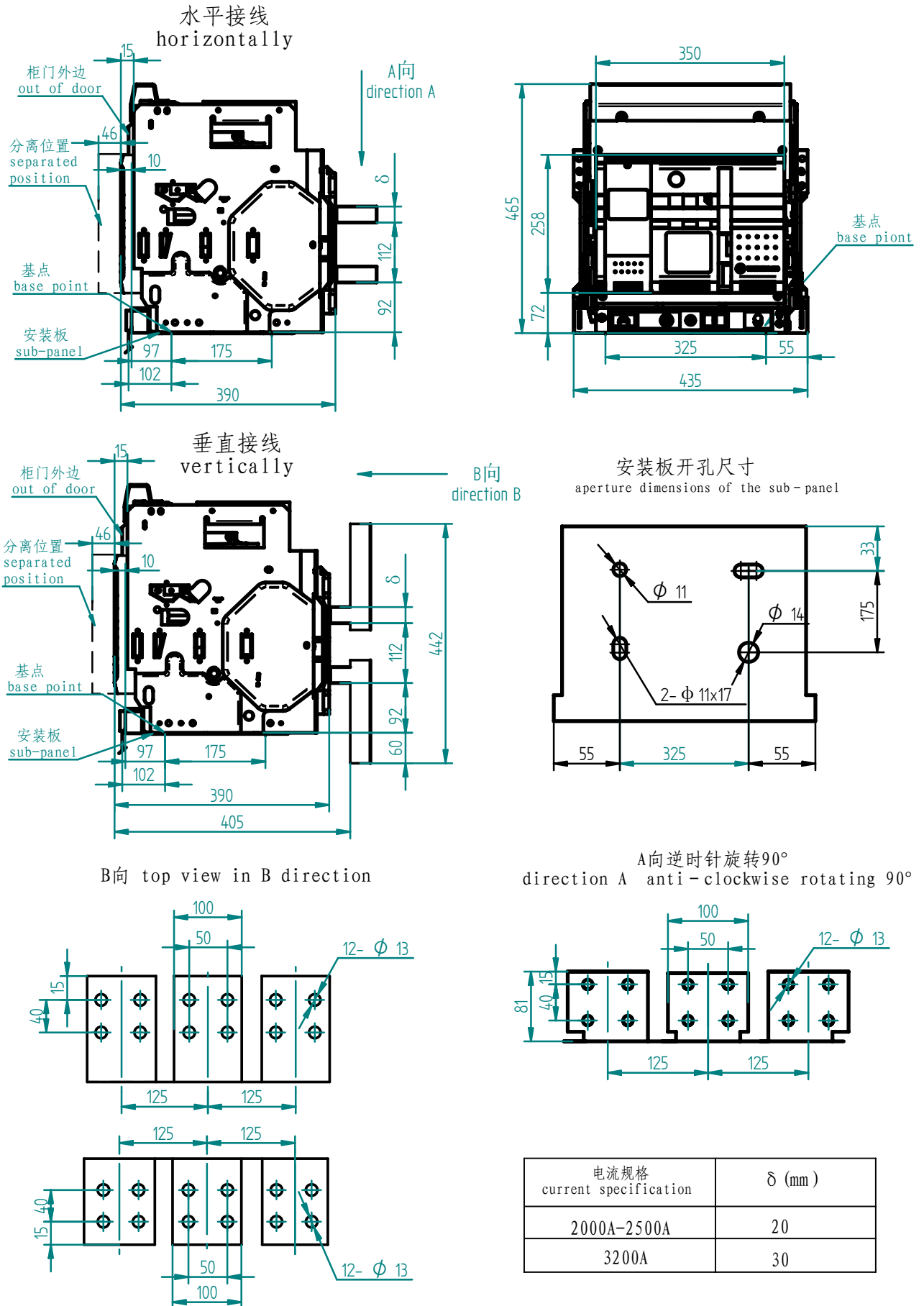

图 28
figure 28

- GSW1-3200/3P+N 抽屉式断路器外形尺寸、安装尺寸见图29
- Mounting dimensions and Outline dimensions of GSW1-3200/3P+N breaker (draw-out) see figure 29

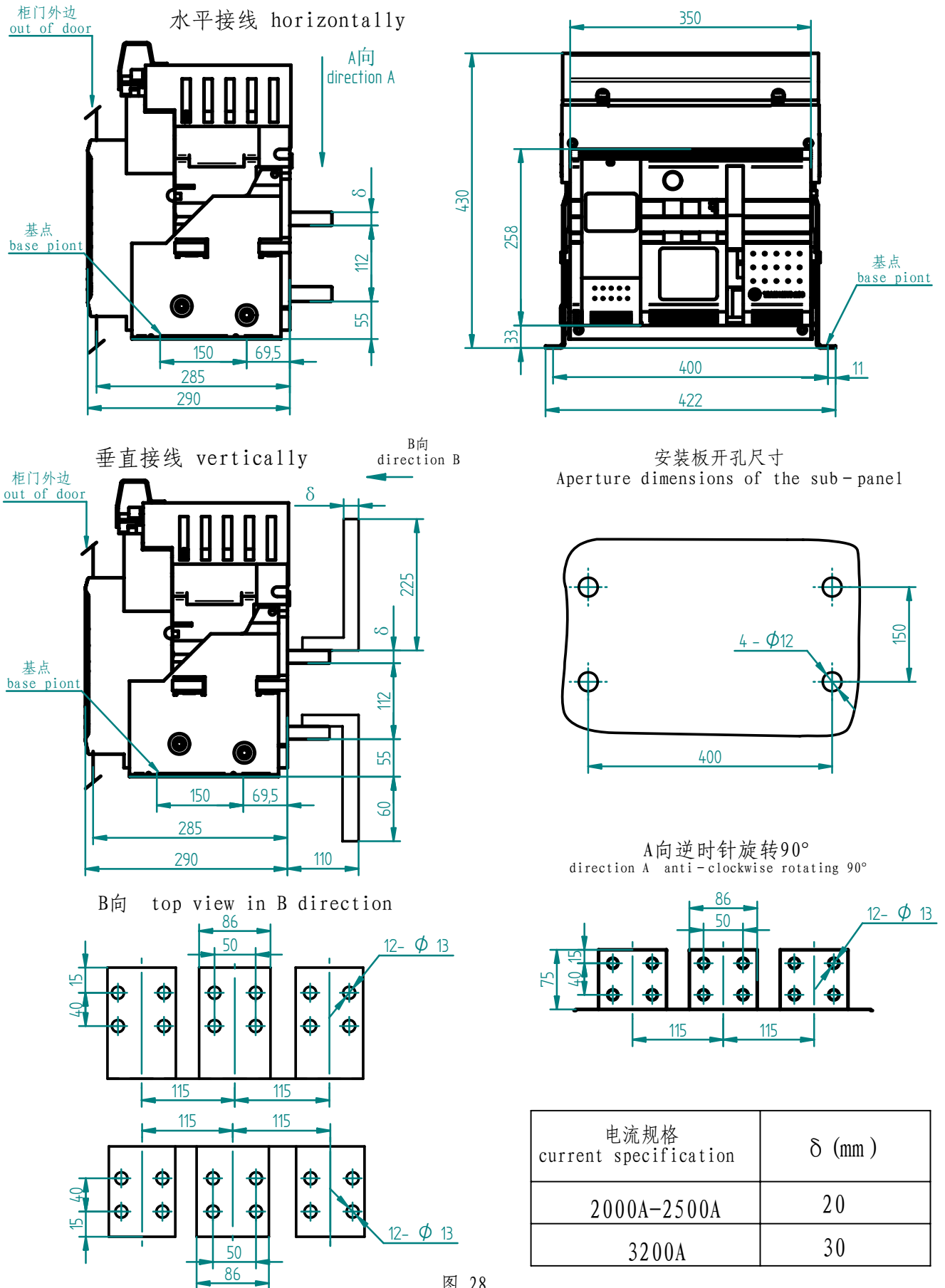

图 29
figure 29

- GSW1-3200/3P+N 固定式断路器外形尺寸、安装尺寸见图30
- Mounting dimensions and Outline dimensions of GSW1-3200/3P+N breaker (fixed) see figure 30

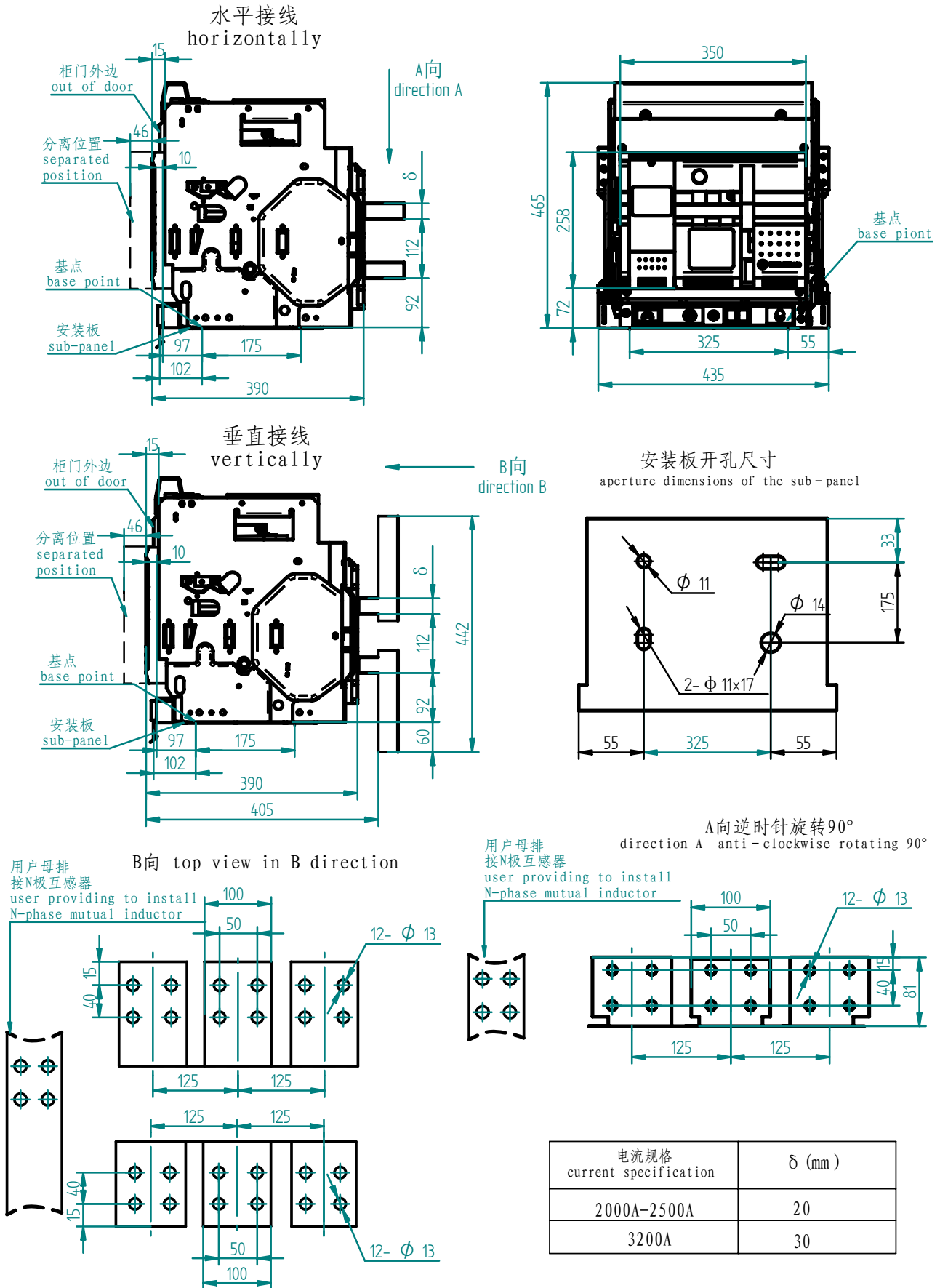

图 30
figure 30

- GSW1-3200/4 抽屉式断路器外形尺寸、安装尺寸见图31
- Mounting dimensions and Outline dimensions of GSW1-3200/4 breaker (draw-out) see figure 31

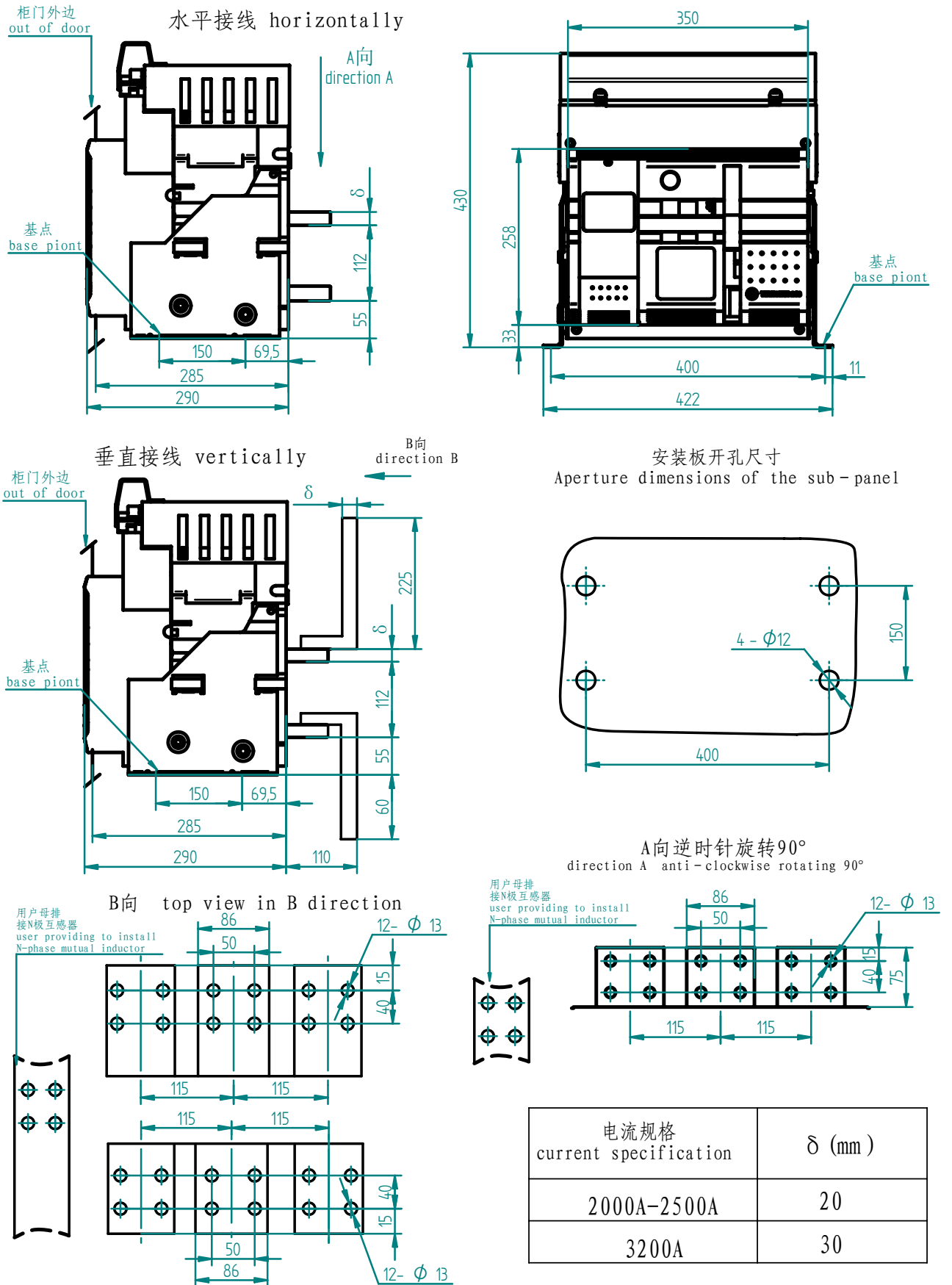

图 31
figure 31

外形及安装尺寸

OUTLINE AND MOUNTING DIMENSIONS

- GSW1-3200/4 固定式断路器外形尺寸、安装尺寸见图32
- Mounting dimensions and Outline dimensions of GSW1-3200/4 breaker (fixed) see figure 32

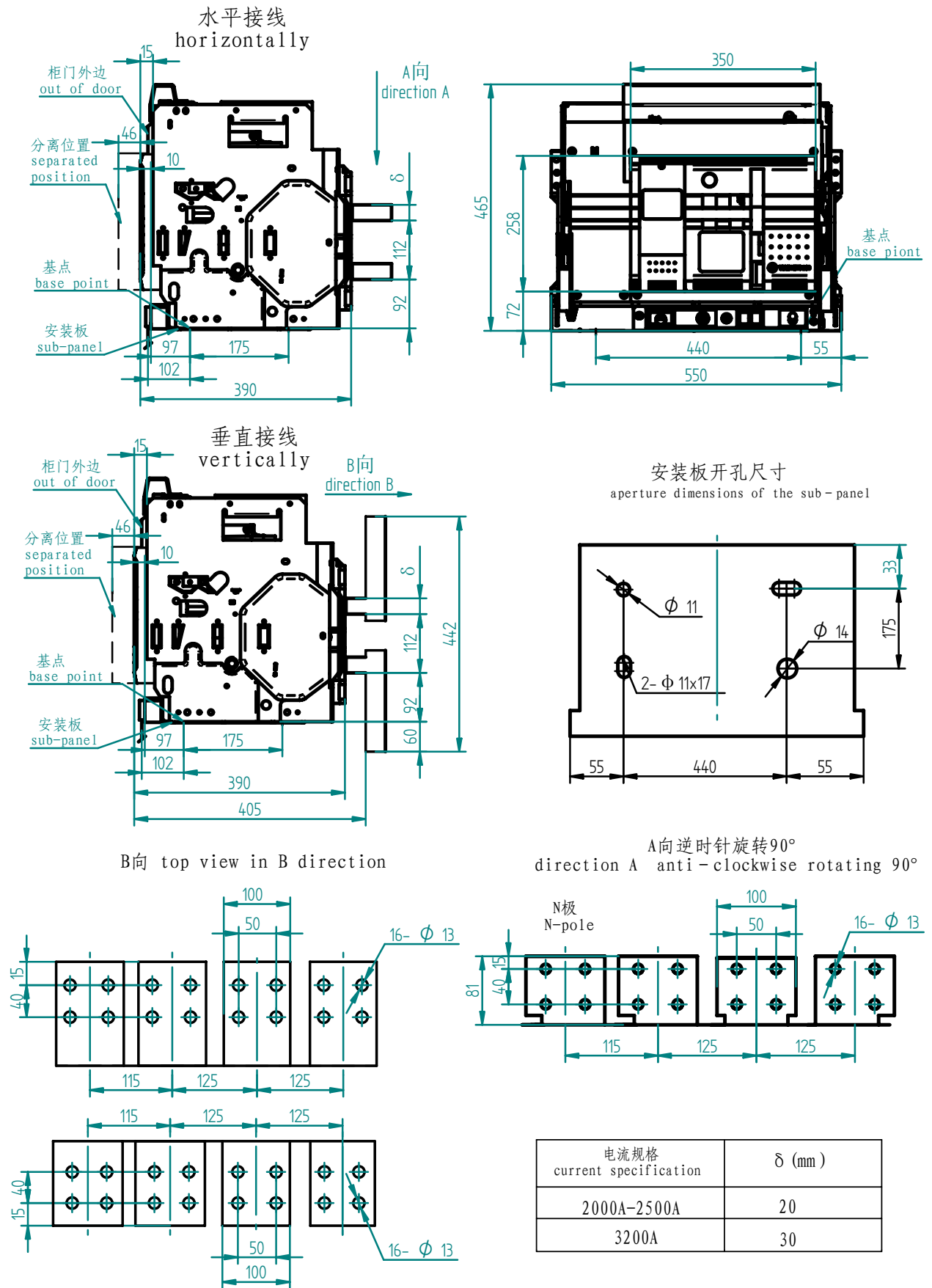

图 32
figure 32

外形及安装尺寸

OUTLINE AND MOUNTING DIMENSIONS

- GSW1-4000/3 抽屉式断路器外形尺寸、安装尺寸见图33
- Mounting dimensions and Outline dimensions of GSW1-4000/3 breaker (draw-out) see figure 33

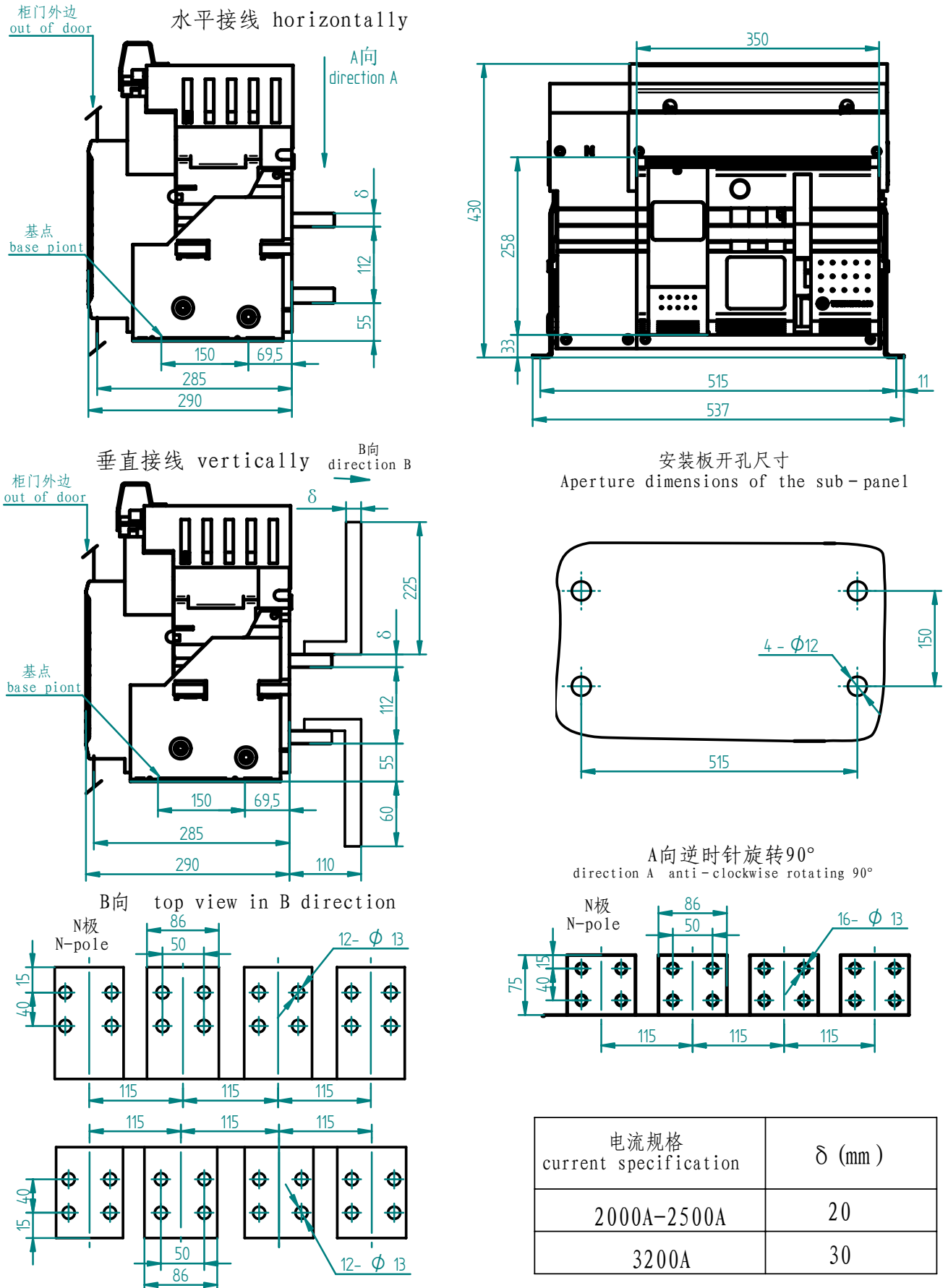
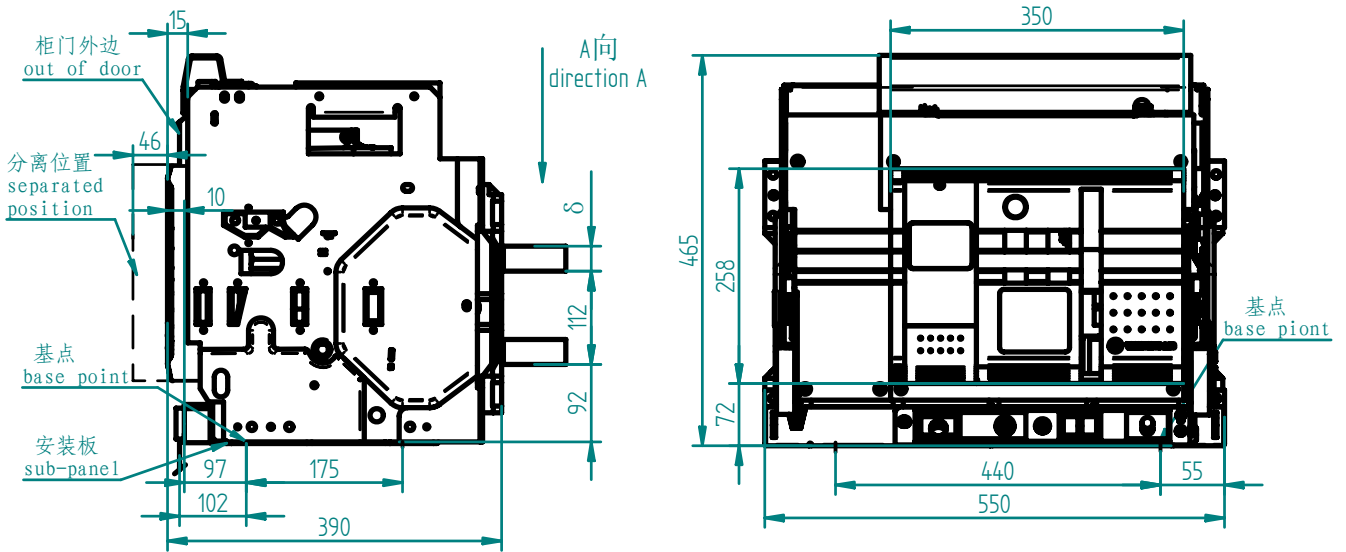

A向逆时针旋转90°
direction A anti-clockwise rotating 90°

安装板开孔尺寸
aperture dimensions of the sub-panel

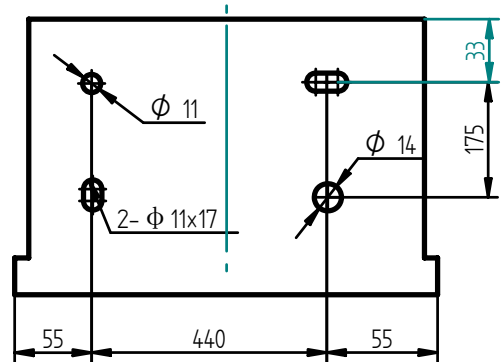
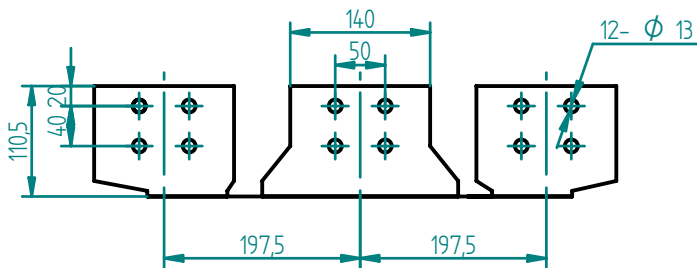

电流规格 current specification	δ (mm)
4000A	30

图 33
figure 33

外形及安装尺寸

OUTLINE AND MOUNTING DIMENSIONS

- GSW1-4000/3P+N 抽屉式断路器外形尺寸、安装尺寸见图34
- Mounting dimensions and Outline dimensions of GSW1-4000/3P+N breaker (draw-out) see figure 34

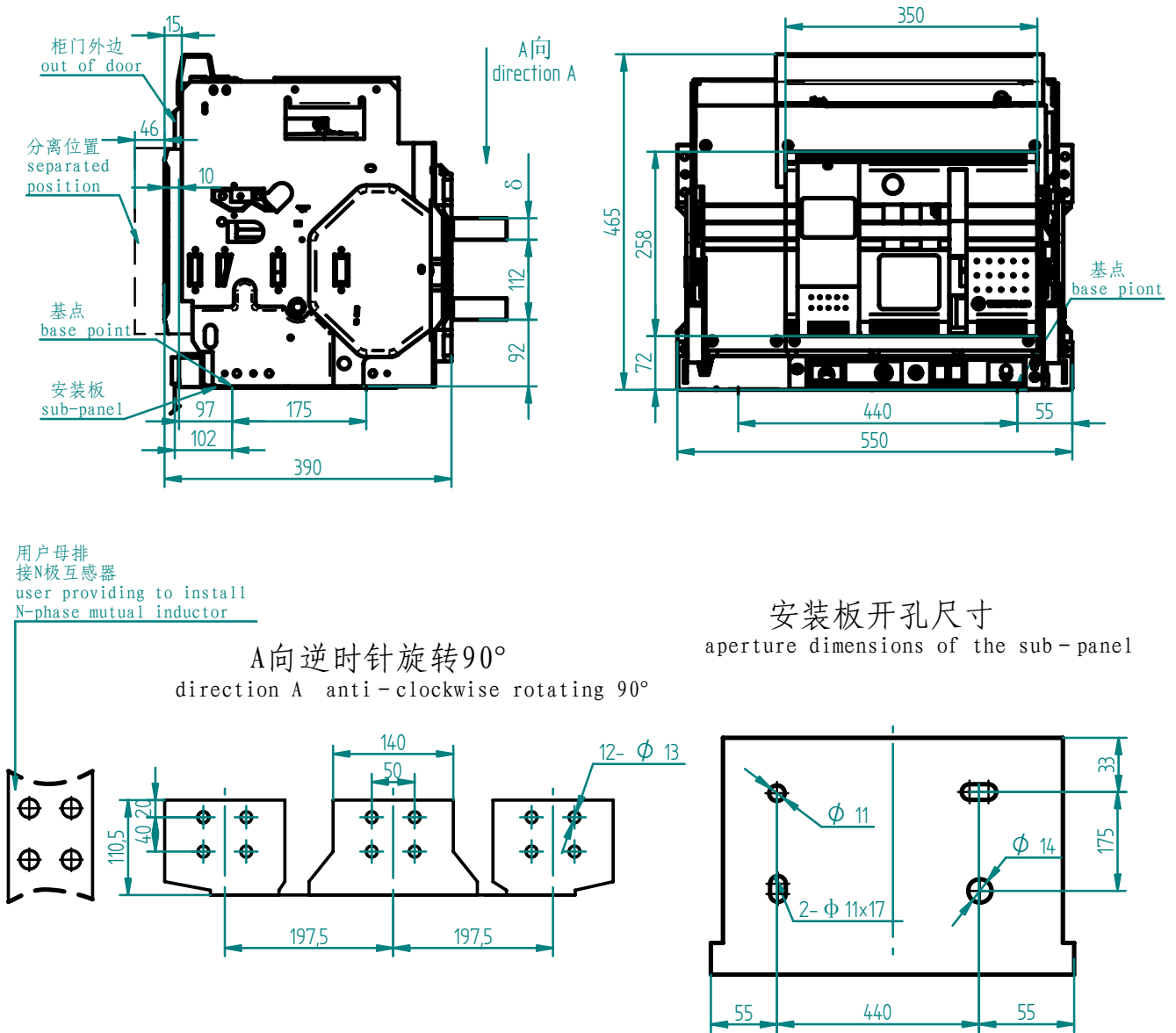

电流规格 current specification	δ (mm)
4000A	30

图 34
figure 34

- GSW1-6300/3 抽屉式断路器外形尺寸、安装尺寸见图35
- Mounting dimensions and Outline dimensions of GSW1-5000/3 breaker (draw-out) see figure 35

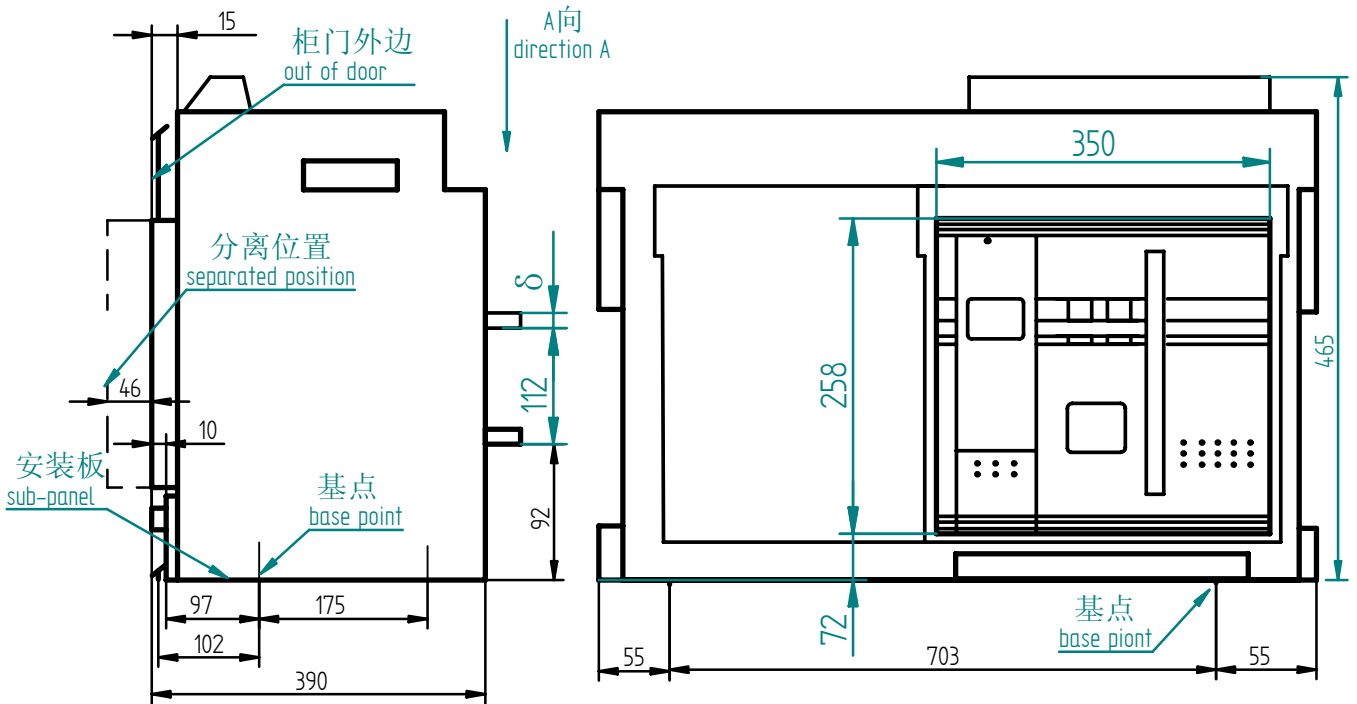

A向逆时针旋转90°
direction A anti-clockwise rotating 90°

安装板开孔尺寸
aperture dimensions of the sub-panel

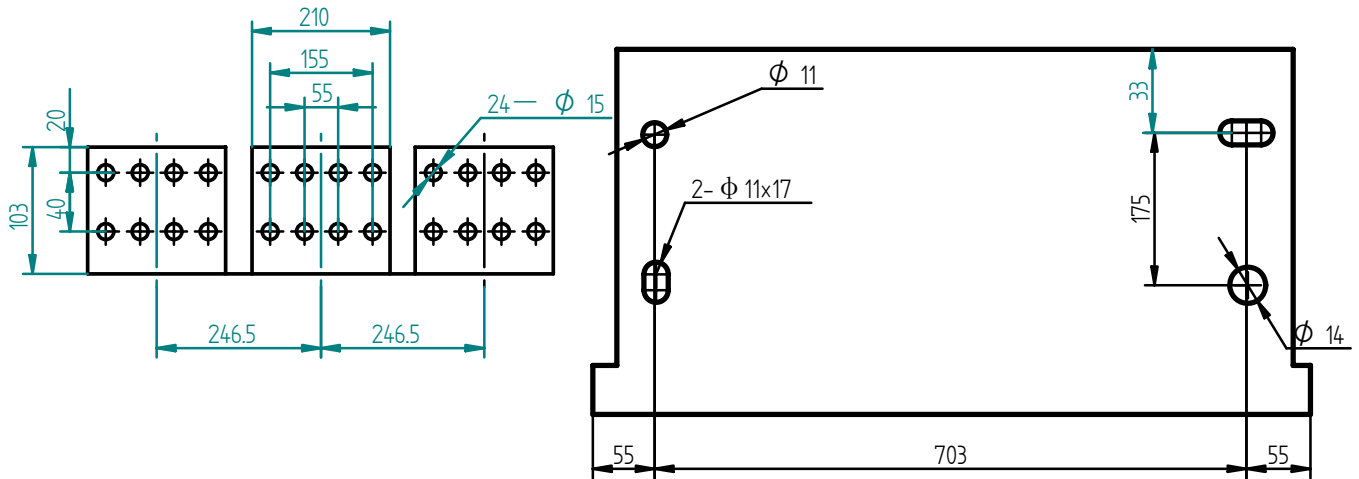

电流规格 current specification	δ (mm)
5000A	30
4000A	20

图 35
figure 35

外形及安装尺寸

OUTLINE AND MOUNTING DIMENSIONS

- GSW1-6300/3 固定式断路器外形尺寸、安装尺寸见图36
- Mounting dimensions and Outline dimensions of GSW1-6300/3 breaker (draw-out) see figure 36

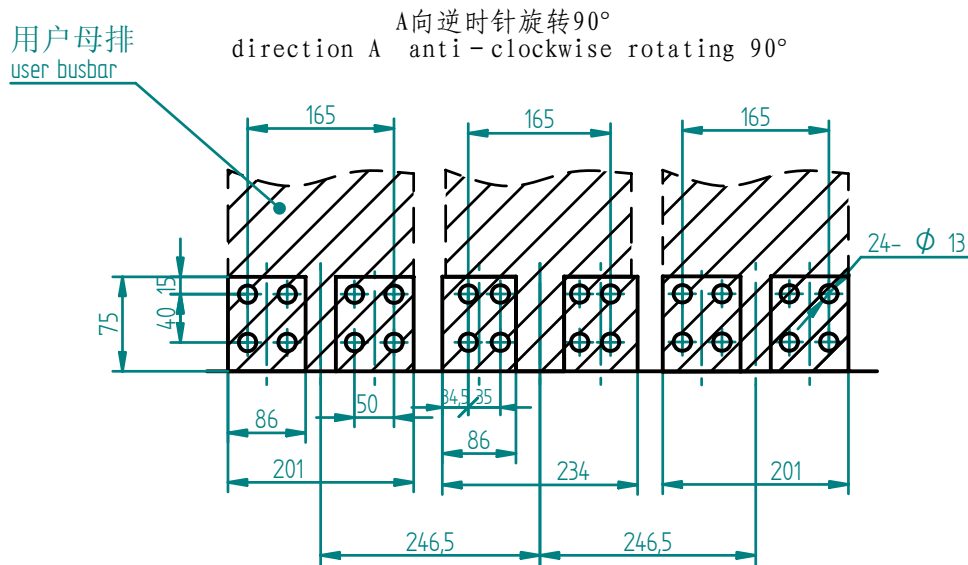
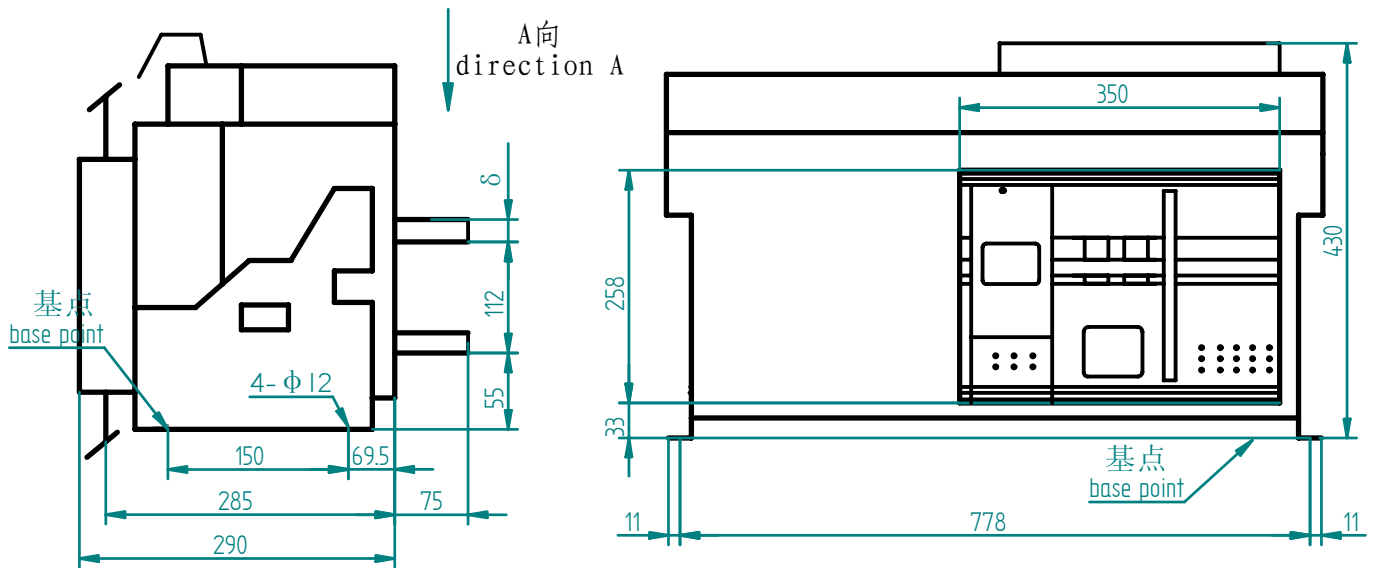

电流规格 current specification	δ (mm)
4000A	20
5000A、6300A	30

图 36
figure 36

外形及安装尺寸

OUTLINE AND MOUNTING DIMENSIONS

- GSW1-6300/4 抽屉式断路器外形尺寸、安装尺寸见图37
- Mounting dimensions and Outline dimensions of GSW1-6300/4 breaker (draw-out) see figure 37

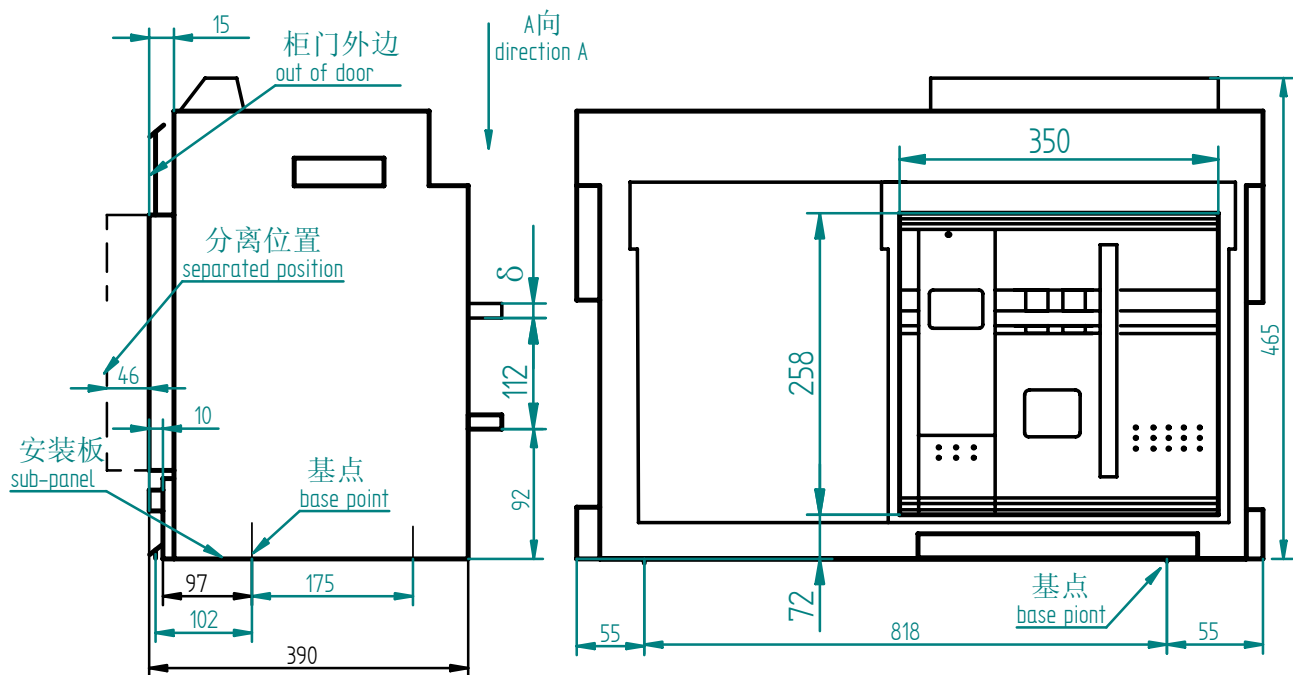

A向逆时针旋转90°
direction A anti-clockwise rotating 90°

安装板开孔尺寸
aperture dimensions of the sub-panel

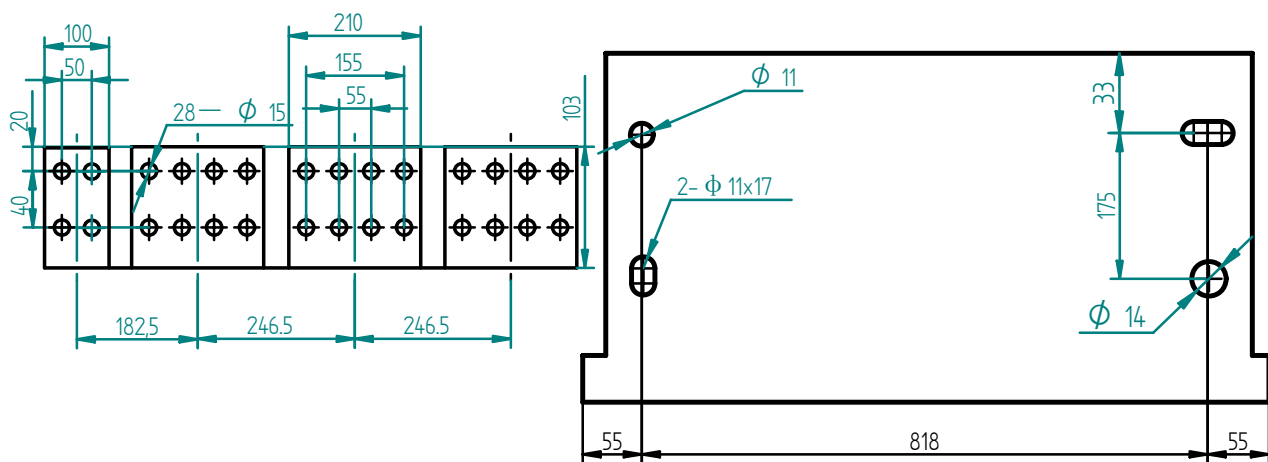

电流规格 current specification	δ (mm)
4000A	20
5000A	30

图 37
figure 37

- GSW1-6300/4 抽屉式断路器外形尺寸、安装尺寸见图38
- Mounting dimensions and Outline dimensions of GSW1-6300/4 breaker (draw-out) see figure 38

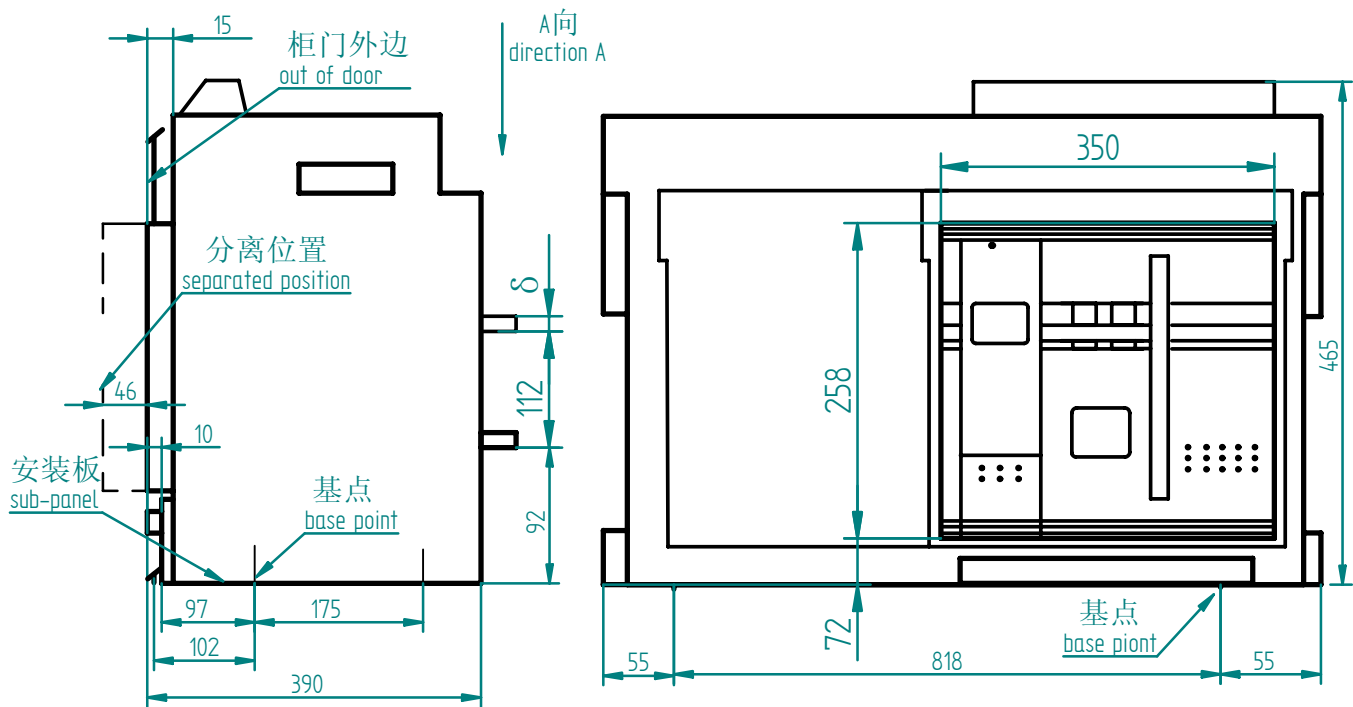

A向逆时针旋转90°
direction A anti-clockwise rotating 90°

安装板开孔尺寸
aperture dimensions of the sub-panel

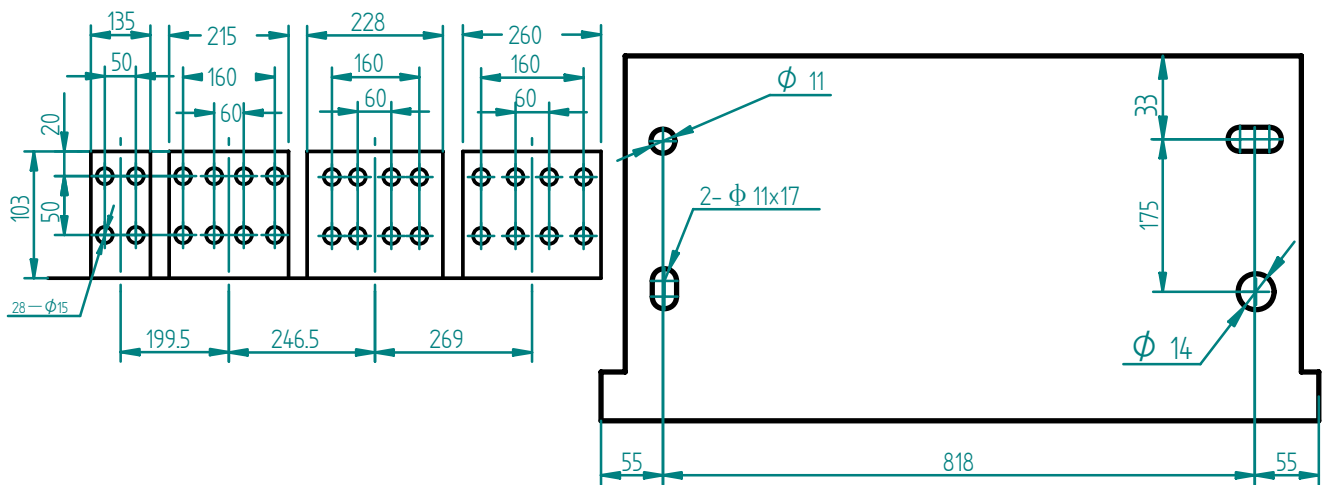

电流规格 current specification	δ (mm)
6300A	30

图 38
figure 38

- 柜门开孔尺寸和安装尺寸见图39
- Holing dimensions and mounting dimensions for door frame see figure 39
- GSW1-1600/L、M型系列柜门开孔尺寸和安装尺寸
GSW1-1600 Holing dimensions and mounting dimensions for door frame

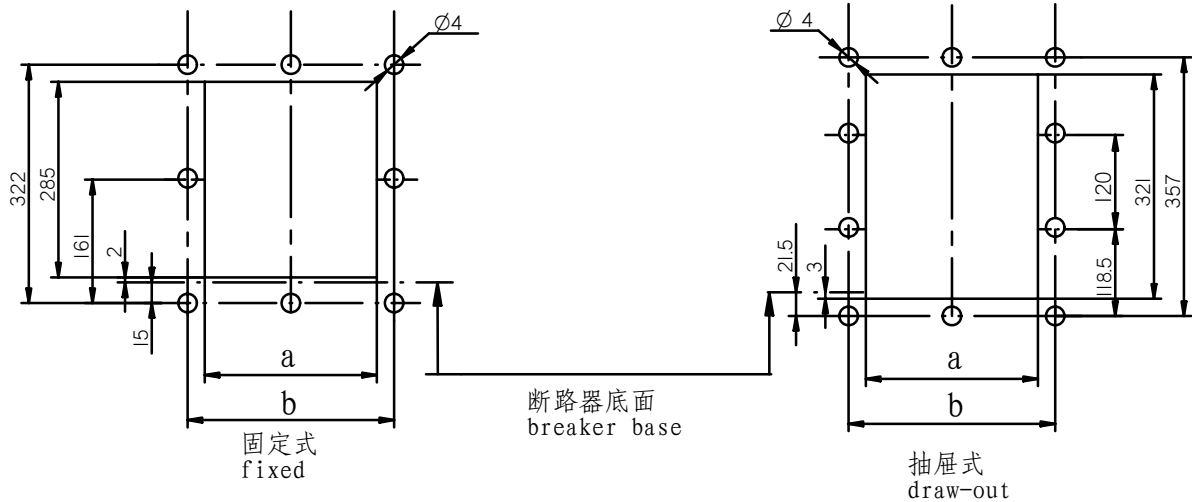

注：GSW1-1600/3H和GSW1-1600/4H型系列柜门开孔尺寸通用GSW1-1600/3M柜门开孔尺寸

- GSW1-2000 ~ 6300柜门开孔尺寸和安装尺寸
GSW1-2000 ~ 6300 Holing dimensions and mounting dimensions for door frame

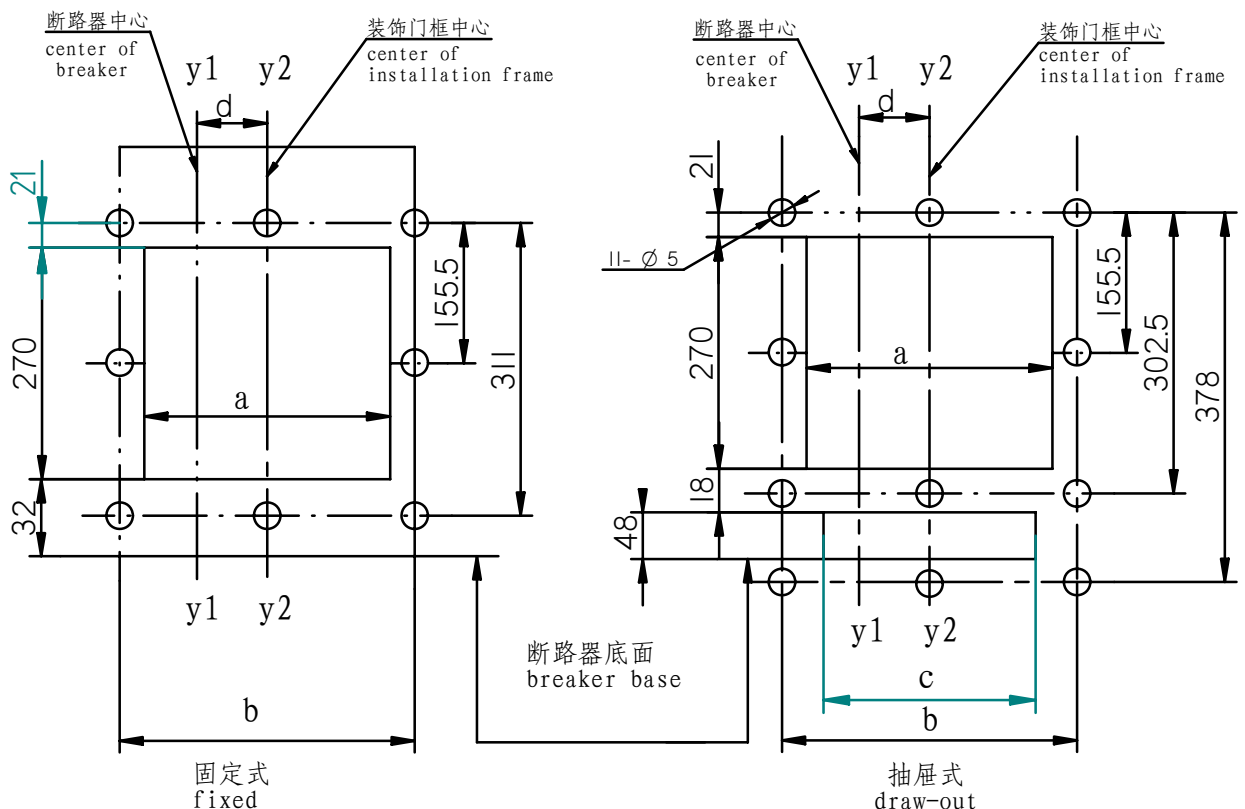

注：1. y1-y1为断路器的中心；y2-y2为柜门装饰门框的中心；
2. d为y1-y1与y2-y2的偏移量。

Note: 1. "y1-y1" is center of breaker; "y2-y2" is center of cupboard's installation frame;
2. "d" is the offset between "y1-y1" and "y2-y2".

Inm (A)	1600/3	1600/4	2000/3	2000/4	3200/3	3200/4	4000/3	(固定式) 6300/3	(抽屉式) 6300/3(4000、5000A)	(抽屉式) 6300A、6300/4
a (mm)	221	291	303	303	363	363	363	363	363	363
b (mm)	257	327	345	345	405	405	405	405	405	405
c (mm)	/	/	260	260	322.5	322.5	322.5	322.5	322.5	322.5
d (mm)	/	/	0	47.5	0	57.5	57.5	189	189	246.5

图39
figure 39

● 安装示意图40
installation rough draft 40

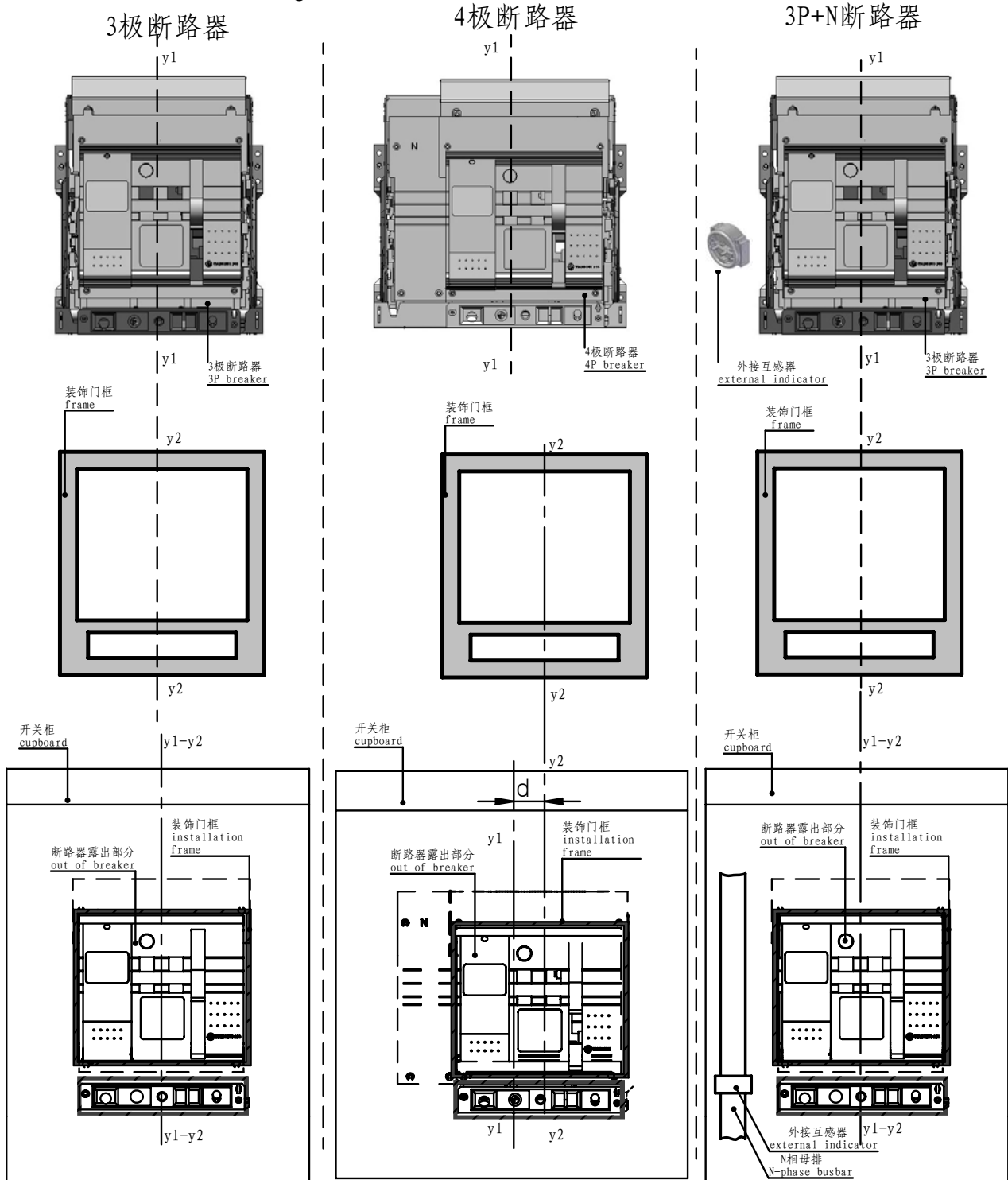

安装正面 front

图40
figure 40

● 安装前先检查断路器的规格是否符合要求。

● 安装前先以1000V兆欧表检查断路器绝缘电阻，在周围介质温度为 $20^{\circ}\text{C} \pm 5^{\circ}\text{C}$ 和相对湿度为50%~70%时绝缘电阻应不小于 $20\text{M}\Omega$ ，否则应烘干，待绝缘电阻达到要求方可使用。

● 断路器安装时，其底座应居于垂直于水平位置，并用M10螺钉固定。

● 安装时对断路器进行可靠的接地保护，接地处有明显的接地标记，固定式断路器应严格遵守安全区。

● 断路器安装完毕按有关接线图接线后，在主电路通电前（抽屉式断路器即抽屉座上的指示指在试验位置）应进行下列操作试验。

● 上下扳动面罩上的手柄六次后面板显示“贮能”并听“咔嚓”一声，贮能结束，按动合闸按钮，断路器可靠闭合（在控制器复位情况下）。

● 接通电动操作机构电源，电动机通电操作至面罩显示“贮能”，并伴随“咔嚓”一声，贮能结束电动机自动断。

● 断路器闭合后，用面罩上的分闸按钮，智能控制器的脱扣试验均应使断路器断开。

● 断路器的插入
拉出抽屉座上的左右滑板，把断路器放上滑板，将滑板推进抽屉座，利用手柄（在抽屉座左下方）的顺时针方向摇动，断路器将由“分离”位置向里推进，经“试验”位置，最后到达“连接”位置，在断路器到达“连接”位置时，可以听到两声清脆的“嗒嗒”声，表示断路器插入已到位。

● 断路器的抽出
处于“连接”位置的断路器，可以通过逆时针方向摇手柄抽出断路器。当指示器指向“分离”位置后，需拔出手柄，然后利用滑板把断路器从抽屉座内抽出（若未拔去摇手柄，断路器将无法抽出）抓住断路器两侧的手柄，可以把断路器从抽屉座上取下。

● Check the specifications of breaker in or out accordance with the requirement of order.

● Checking the insulating resistance with a 500V mega meter, the resistance should not be less than $20\text{M}\Omega$ when ambient temperatures is $20^{\circ}\text{C} \pm 5^{\circ}\text{C}$ and relative humidity is 50-70%, otherwise it should be dried till the insulating resistance meet the requirement.

● When installed, the base should be in the vertical lever and fastened with M10 screw.

● When installed, breaker should be protected with reliable earth connection. There is obvious earth connection remark. The fixed breaker should abide by strictly safe area.

● After finished installation and wiring according with the wiring diagram, and before the main circuit is supplied current (the signal on the draw-out base shows the test position) the operation test can be carried out.

● Turn the handle on 7 times until a click comes and indicator shows "energy-storage" that it tells the energy-storage process finished. At the same time, press the closing button or the closing electromagnet, the breaker could be closed reliably (under the controller's reset condition).

● After the motor device's power is supplied, the motor is on and the surface Shows "energy-storage", and a click comes. The energy storage process finished and the motor's current is cut off automatically. Press the closing button or the closing electromagnetic.

● As the breaker closed, the breaker could be released, whatever using the under voltage release, shunt release or the cut-off button on the surface.

● Breaker's insertion Pull out the draw-out base's right and left slide board, place the breaker on the slide board and push the slide board into the draw-out base. Utilize the handle (located in the left-down of the draw-out base) to clockwise rotate, and the breaker moves inside from the separate position, pads by test position and finally get to the link position. As the breaker get to the link position, two sounds of click can be heard, which means the breaker's insertion is in place.

● Breaker's withdrawal Breaker in the link position, can be withdrawal by anticlockwise rotating the handler. When the indicator shows the separate position. The handler needs to be pulled out (if the handler has not been pulled out, the breaker can not withdrawal), then the breaker is withdrawn along with the slide board. Catching hold of the two sides of the breaker, the breaker is taken off from the draw-out base.

- 断路器在插入抽屉座前必需处于断开状态。处于“试验”位置的断路器，二次电流已接通，可进行试验操作。
- 接入两台断路器的电源相须必须一致，两路电源的各自的N极不能接错。
- 保护接地应可靠，以确保使用安全。
- 控制器和电缆要联接好。
- 对于F型，要外接电源(DC12V)。

- Before insert breaker to the draw-out base, the breaker must be in the separate the test operation can be carried out.
- Phase sequence of the two breakers should be same, pay attention to the two different neutral lines of the two breakers.
- To ensure safely, grounding should be in good condition.
- Cable is good used to link with the controller.
- It must connect external power supply (DC12V) for type F.

表 11 table 11

现象 Phenomenon	产生原因分析 Causes analysis	排除方法 Exclusion methods
断路器不能合闸 The breaker can't close	断路器故障动作后，其面板上部红色按钮没有复位。 forget to press the reset-button on the panel after the breaker broke away	按下复位按钮 press the reset-button
	抽屉式断路器本体没有摇到位。 Draw out breaker has not been put in place	将本体摇到位，听到“咔、咔”响声为止 put the draw out breaker in the right place, until hearing the sound "ka ka"
	闭合电磁铁出现如下问题： 1. 用万用表测量闭合电磁铁线圈电阻无穷大，则线已断；或是线圈外引线已断； 2. 与闭合电磁铁配合的机构上白色“小飞机”出轨，导致闭合电磁铁杆不能与之接触而不合闸，出现此种情况手动也不能合闸。 The following problems appears on the closed electromagnet: 1. If the electric resistance is infinite high by a multimeter, shows that the wiring is broken. or The external line of the coil is broken 2. The white "small plane" in the device conforming to the closed electromagnet goes off the rails. The closed electromagnetic traveler can not be touched if this problem appears, and it can not be closed manually	1. 更换工作电压 U_e 相符的闭合电磁铁；若电压偏高，要求用户降低电压； 2. 拆掉闭合电磁铁，查看下面白色“小飞机”，若出轨则用螺刀让其入轨。 1. Exchange the closed electromagnet conforms to the working voltage. If the voltage is high, lower the voltage first; 2. Take off the closed electromagnet and check the white "small plane" if it goes off the rails, put it in place by a screw driver
断路器不能电动储能 The breaker can not electrically store energy	1. 电操机构电源未接通； 2. 电源容量不够； 3. 电操中电动机烧毁。 1. The motor operation is not wired 2. Power supply volume is not enough 3. The motor in the motor operation is burned	首先用万用表测34#、35#端子电压，其值必须大于85% U_s ，否则检查电源。其次用万用表测34#、35#两端的电阻值，若为无穷大，则电动机烧毁，要更换电动操作机构。 Firstly use the multimeter to measure 34#. 35# terminal voltage, And the value must be lager 85% U_s , otherwise check the power supply. Secondly use the multimeter to measure the resistance value of 34#, 35# on both ends. If the value is infinite, it shows the motor burned, and exchange motor operation device.
分励脱扣器不能使断路器断开 The shunt release can not break down the breaker	分励脱扣器断线或烧毁。 The shunt release's wire break off or burned	拔掉29#、30#端子，用万用表欧姆档测电阻，若为无穷大，则分励脱扣器已坏。 take down the terminal 29#, 30#. and measure the resistance by the ohm gear of the multimeter, if the value is infinite, the shunt release is broken.
抽屉式断路器在断开位置时不能抽出断路器 Draw out type in the separate position, the breaker can not be pulled out	1. 手柄未拔出； 2. 断路器没有完全到达断开位置。 1. The handler is not withdrawal 2. The breaker is not fully in the separate position.	拔出手柄，若还不能抽出，则重新插入手柄，摇到断开位置。 Take out of the handler, if it can not be withdrawn, and then insert the handler again, rotate it in the separate position
闭合电磁铁或分励脱扣器不动作 Closing electromagnet or shunt does not work	二次回路接线端子配合不好，接触不良。 There be not matched up greatly between secondary circuit wiring terminals, which leads to connect weakly.	断电摇开本体与抽屉架，查看二次回路接线端子金属片的配合情况，若有弯曲等现象，则校正，并在插入时注意配合。 cut the electricity off, rotate off the body and the frame of drawer, check the match of the metal blade of the secondary circuit wiring terminals, if it is bent, amend it and match up greatly.

●如用户订货时无特殊要求，GSI智能控制器出厂整定值按如表12配置。

●GSI The intelligenet controller would be configured as table 12, if no special demands was put forward when ordering.

表 12 table 12

过载长延时 Overload long-delay	电流整定值Ir1 Current setting Ir1	In
	延时时间整定值t1 Delay time setting t1	240s
短路短延时 Short-circuit short-delay	电流整定值Ir2 Current setting Ir2	6Ir1
	延时时间整定值t2 Delay time setting t2	0.4s
短路瞬时电流整定值Ir3 Short-circuit instantaneous current setting Ir3		10Ir1
接地故障 Earthed errors	电流整定值Ig Current setting Ig	OFF
	延时时间整定值tg Delay time setting tg	OFF
负载监控 Load monitoring	监控电流ILC1 Monitoring current ILC1	Ir1
	监控电流ILC2 Monitoring current ILC2	Ir1

●如用户订货时无特殊要求，过压值、欠压值和断路器的转换动作时间出厂整定值如表13所示。

●over-voltage、under-voltage and delay acting time would be configured as table 13, if no special demands was put forward when ordering.

表 13 table 13

过压值 Over-voltage	276V (Un*125%)
欠压值 Under-voltage	160V (Un*72%)
转换断开延时时间t1 Delay time t1 before power supply switching off while switching operation	1S
转换接通延时时间t2 Delay time t2 before power supply switching on while switching operation	3S
返回断开延时时间t3 Delay time t3 before power supply switching off while restoring operation	1S
返回接通延时时间t4 Delay time t4 before power supply switching on while restoring operation	3S
t5: 卸载延时时间t5 Delay time t5 before giving out of the command of unload	3S
t6: 发电延时时间t6 Delay time t6 before giving out of the command of power generation	3S

自动转换开关控制器
the controller of the automatic switch

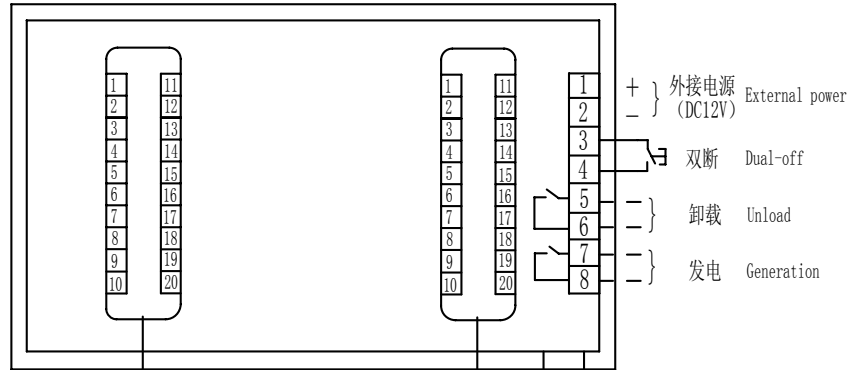

常用断路器
normal breaker

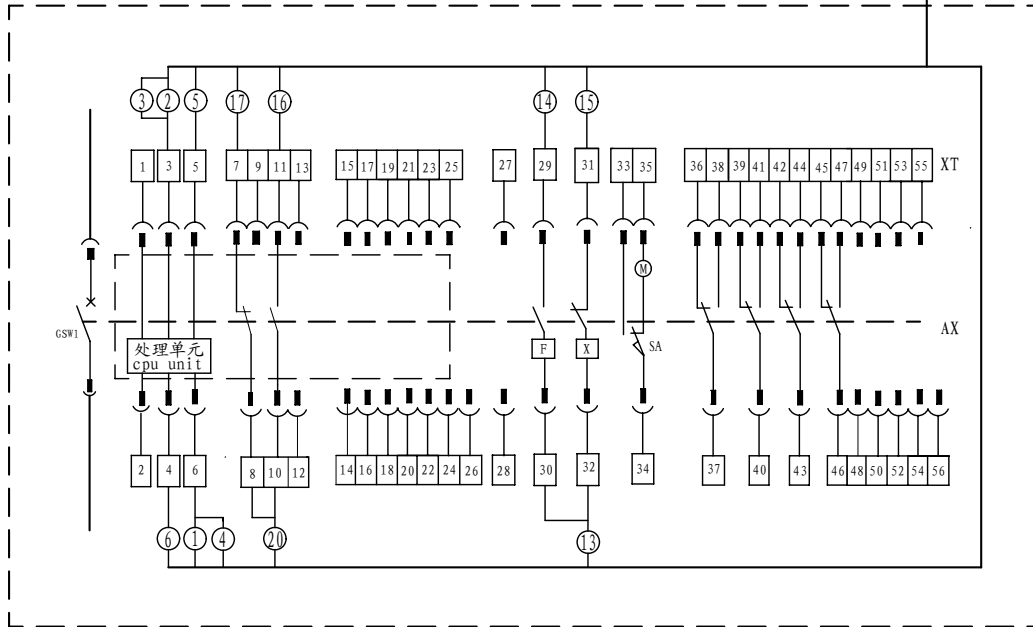

备用断路器
reserve breaker

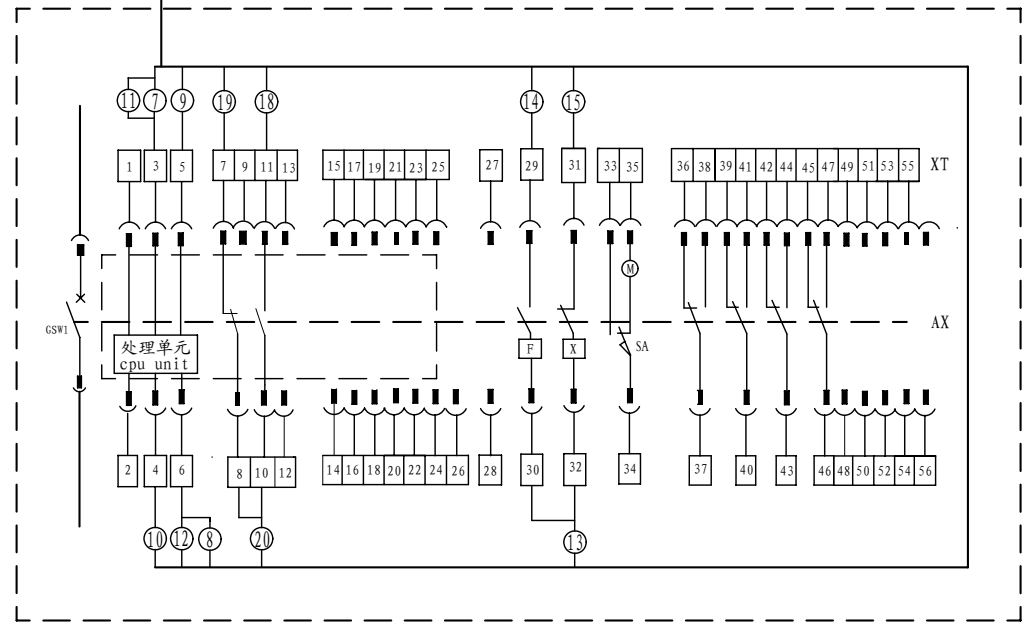

GSA1-1600 / L、M型自动转换开关本体与控制器电气连接图

GSA1-1600/L、M automatic switch's wiring diagram of the main body and the controller

自动转换开关控制器
the controller of the automatic switch

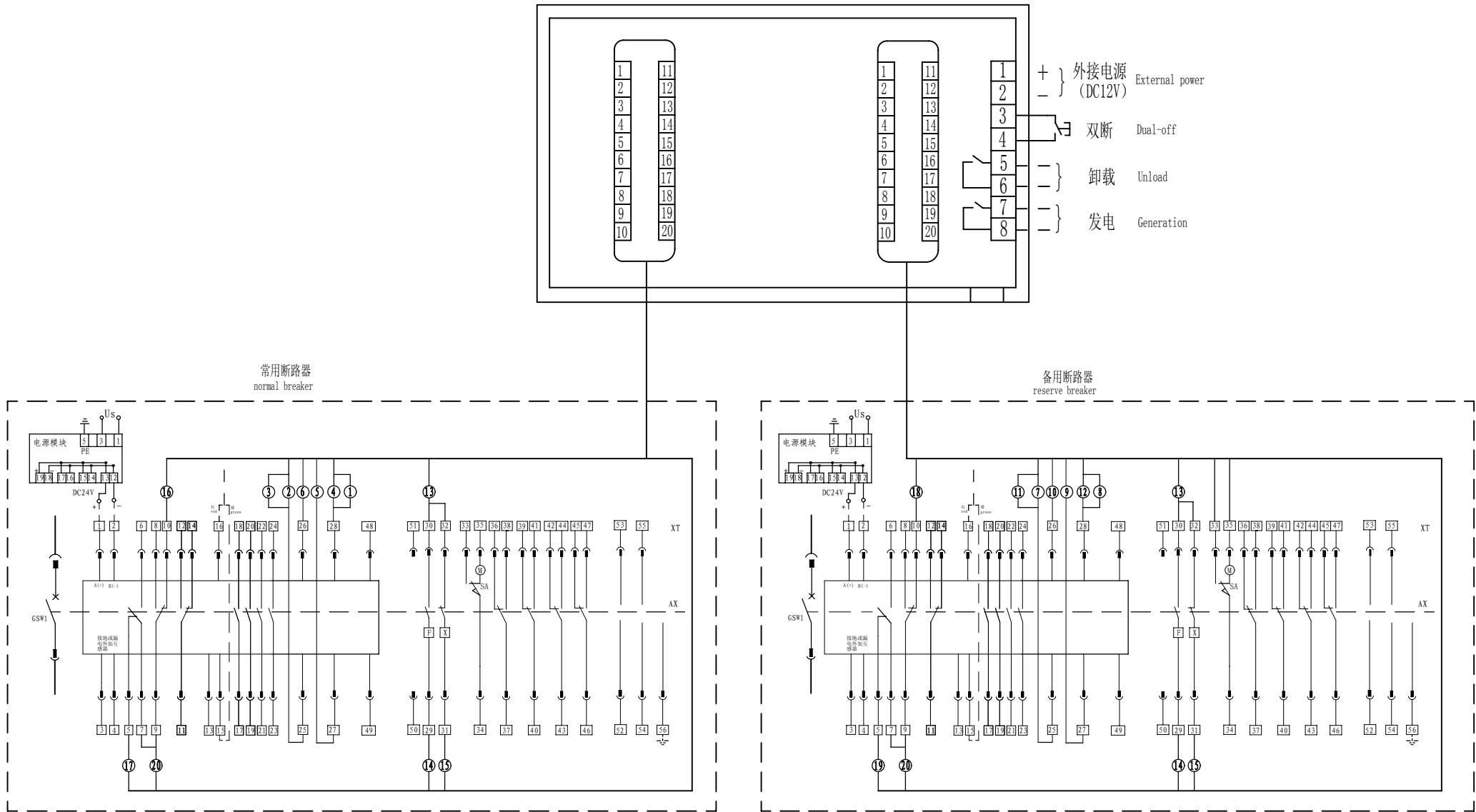

GSA1-1600/ H (通信型) 自动转换开关本体与控制器的电气连接图
GSA1-1600/H automatic switch's wiring diagram of the main body and the controller

自动转换开关控制器
the controller of the automatic switch

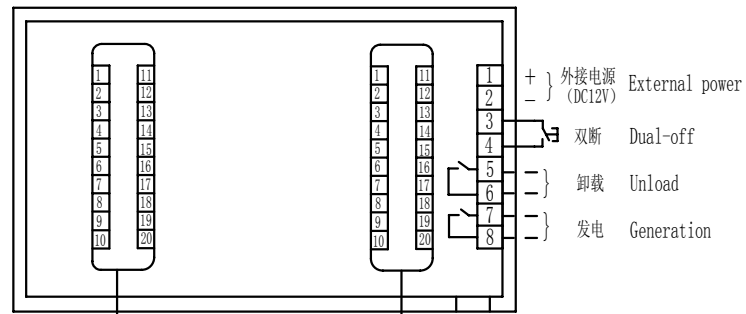

常用断路器
normal breaker

备用断路器
reserve breaker

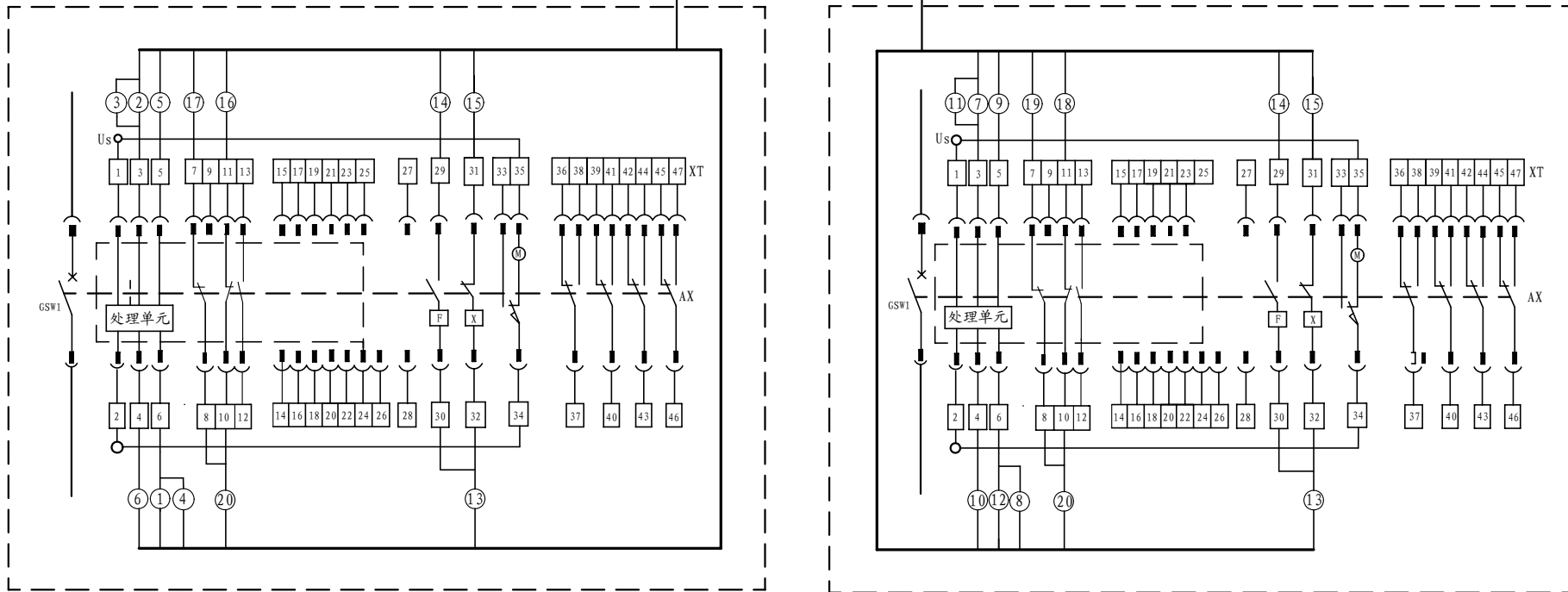

GSA1-2000、3200、4000、6300 / L、M 型自动转换开关本体与控制器的电气连接图

GSA1-2000、3200、4000、6300/L、M automatic switch's wiring diagram of the main body and the controller

自动转换开关控制器
the controller of the automatic switch

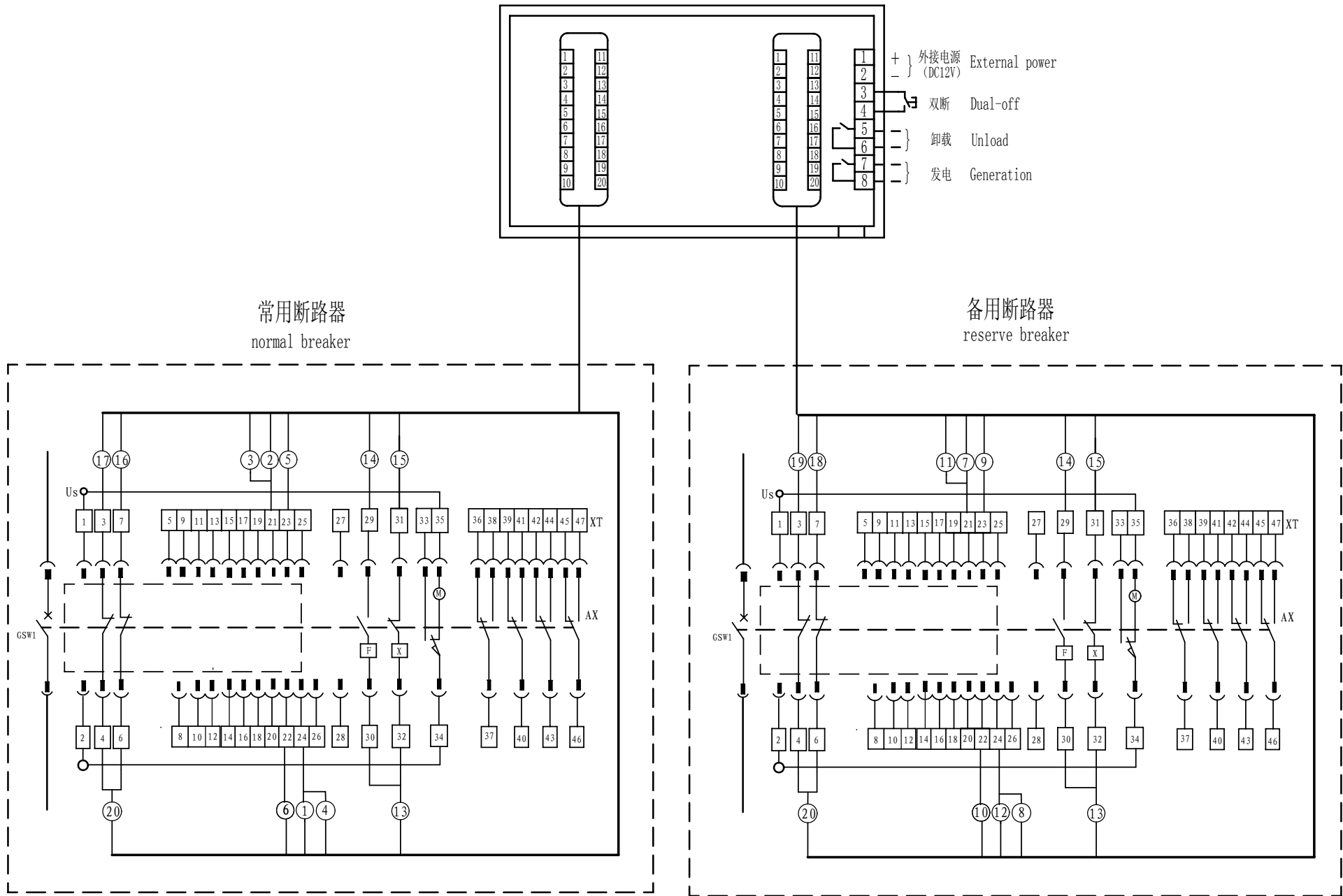

GSA1-2000、3200、4000、6300/ H (通信型) 自动转换开关本体与控制器电气连接图

GSA1-2000、3200、4000、6300/H automatic switch' s wiring diagram of the main body and the controller

常用断路器二次接线电气连接图
Wiring diagram of second circuit equipped for normal breaker

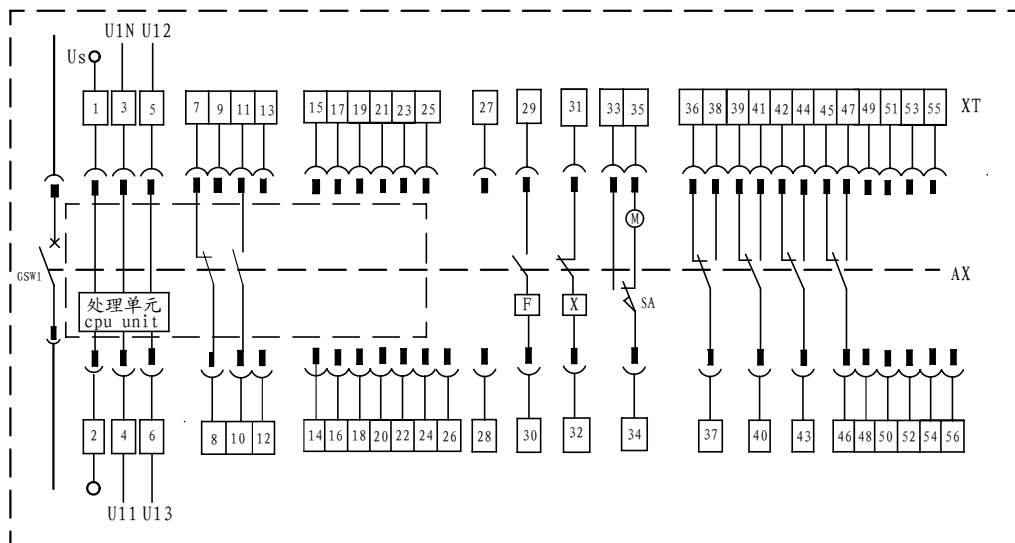

- 注:
- (1) 7、8、9、10、11、12、13、29、30、31、32用户不可以使用，不可以作任何输入、输出点。
 - (2) 1、2端子：为智能控制器外供电DC24V，DC24V电源通过220V电源模块供电。
 - (3) 3、4、5、6端子为常用电源L1N、L11、L12、L13相，接线顺序需正确，L1N极必须接入。
 - (4) 26为接地保护线。
 - (5) 29-30为分励线圈，31-32为闭合电磁铁。
 - (6) 33-34-35为储能电动机，34、35必须接AC220V电源。
 - (7) 36-56为辅助触头（触头容量AC220V，9A）。
 - (8) 当选用3P+N型断路器时，23、24为外接N相互感器输入端。
- AX为断路器辅助开关；XT为断路器二次接线端子；F为分励脱扣器；X为闭合电磁铁；M为储能电机。

- note:
- (1) Users don't used terminal for 7、8、9、10、11、12、13、29、30、31、32, don't used as enter and output.
 - (2) terminal 1、2: wire the extension power for intelligent controller, wire for charging motor, the type is: AC220V.
 - (3) terminal 3、4、5、6 must are wire of normal power L1N、L11、L12、L13 phase corresponding, wiring serial must be correct and the L1N-phase must be wired.
 - (4) earthed terminal: 26
 - (5) terminal 29-30: shunt release, terminal 31-32: closing electromagnet.
 - (6) terminal 33-34-35: motor-driven energy-storage system. 34、35 must be AC220V.
 - (7) auxiliary terminal: 36-56.
 - (8) when breaker chosen as the type of 3P+N, the extension n-phase mutual inductor's signal inputs terminal 23、24.
- AX-auxiliary switch of the breaker; XT-terminal of secondary circuit if breaker;
F-shunt release; X-closing electromagnet; M-charging motor.

备用断路器二次接线电气连接图
Wiring diagram of second circuit equipped for reserve breaker

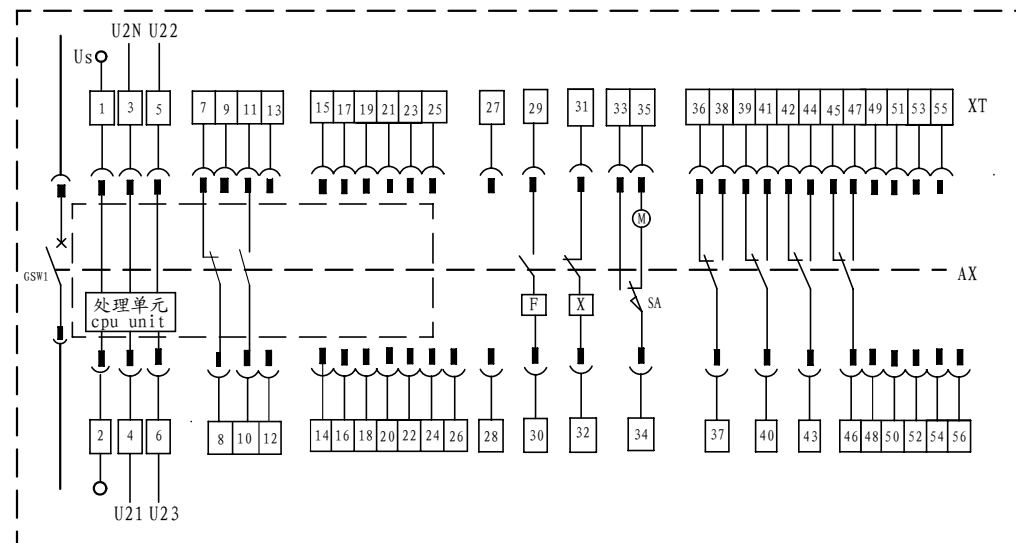

- 注:
- (1) 7、8、9、10、11、12、13、29、30、31、32用户不可以使用，不可以作任何输入、输出点。
 - (2) 1、2端子：为智能控制器外供电DC24V，DC24V电源通过220V电源模块供电。
 - (3) 3、4、5、6端子为备用电源L2N、L21、L22、L23相，接线顺序需正确，L2N极必须接入。
 - (4) 26为接地保护线。
 - (5) 29-30为分励线圈，31-32为闭合电磁铁。
 - (6) 33-34-35为储能电动机，34、35必须接AC220V电源。
 - (7) 36-56为辅助触头（触头容量AC220V，9A）。
 - (8) 当选用3P+N型断路器时，23、24为外接N相互感器输入端。
- AX为断路器辅助开关；XT为断路器二次接线端子；F为分励脱扣器；X为闭合电磁铁；M为储能电机。

- note:
- (1) Users don't used terminal for 7、8、9、10、11、12、13、29、30、31、32, don't used as enter and output.
 - (2) terminal 1、2: wire the extension power for intelligent controller, wire for charging motor, the type is: AC220V.
 - (3) terminal 3、4、5、6 must are wire of reserve power L2N、L21、L22、L23 phase corresponding, wiring serial must be correct and the L2N-phase must be wired.
 - (4) earthed terminal: 26
 - (5) terminal 29-30: shunt release, terminal 31-32: closing electromagnet.
 - (6) terminal 33-34-35: motor-driven energy-storage system. 34、35 must be AC220V.
 - (7) auxiliary terminal: 36-56.
 - (8) when breaker chosen as the type of 3P+N, the extension n-phase mutual inductor's signal inputs terminal 23、24.
- AX-auxiliary switch of the breaker; XT-terminal of secondary circuit if breaker;
F-shunt release; X-closing electromagnet; M-charging motor.

GSAl-1600/L、M自动转换开关常用断路器、备用断路器二次接线电气连接图
Wiring diagram of second circuit equipped for normal breaker and standby breaker of GSAl-1600/L、M frame automatic transfer switching system

常用断路器二次接线电气连接图

Wiring diagram of second circuit equipped for normal breaker

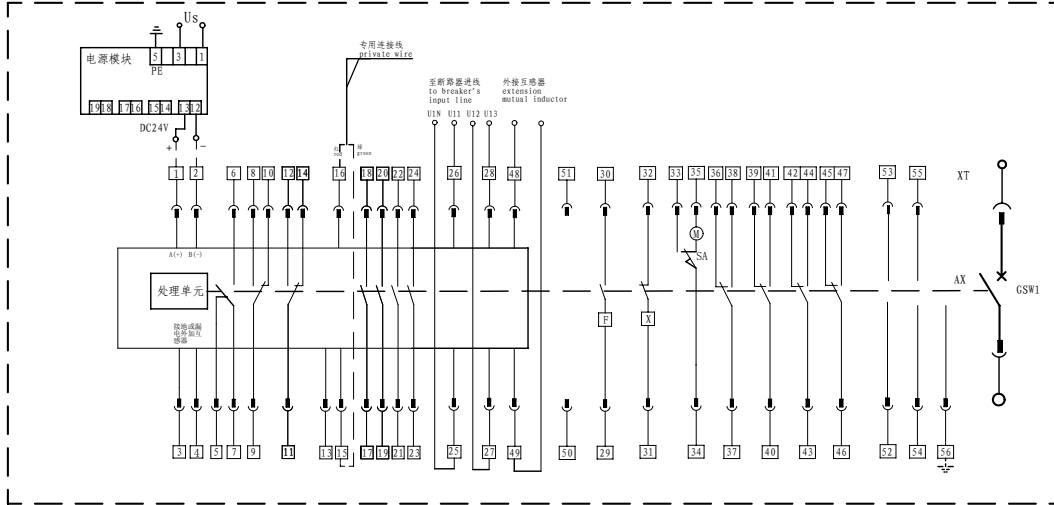

- 注: (1) 1、2端子: 接智能控制器外供电电源DC24V, DC24V电源需通过电源模块供电。
 (2) 3、4为外加接地或漏电互感器。
 (3) 对于5、6、7、8、9、10、11、12、14、29、30、31、32端用户不可使用, 不可作任何输入、输出点。
 (4) 17-24为可编程输入/输出接口, S1型、S2型、S3型。
 (5) 25-28为常用电压输入信号, 依次接入U1N、U11、U12、U13, 接线相序需正确, L1N必须接入。
 (6) 15、16分别为RS485A, RS485B通讯引出线, 13为通讯屏蔽接地线。
 (7) 56接保护地线。
 (8) 29-30为分励脱扣器, 31-32为闭合电磁铁。
 (9) 33-34-35接储能电动机, 34、35接AC220V电源。
 (10) 当选用3P+N型断路器时, 48、49为外接N相互感器输入端。

- note: (1) terminal 1, 2: wire the extension power for intelligent controller, wire for charging motor the type is: AC220V.
 (2) terminal 3, 4: wire the extension earthed or leak current mutual inductor
 (3) Users don't used terminal for 5, 6, 7, 8, 9, 10, 11, 12, 14, 29, 30, 31, 32. don't used as enter and output.
 (4) terminal 17-24: programable I/O interface, type: S1, S2, S3
 (5) terminal 25-28: normal voltage signal input, must be wire of normal power L1N, L11, L12, L13 phase corresponding, wiring serial must be correct and the L1N-phase must be wired.
 (6) terminal 15, 16: wiring RS485A, RS485B correspondence line respectively; 13: earthed terminal
 (7) earthed terminal: 56
 (8) terminal 29-30: shunt release, terminal 31-32: closing electromagnet.
 (9) terminal 33-34-35: motor-driven energy-storage system, 34, 35 must be AC220V.
 (10) when breaker chosen as the type of 3P+N, the extension n-phase mutual inductor's signal inputs terminal 48, 49 power supply-different power supply for different rated voltage of intelligent controller, F, X, M etc.

备用断路器二次接线电气连接图

Wiring diagram of second circuit equipped for reserve breaker

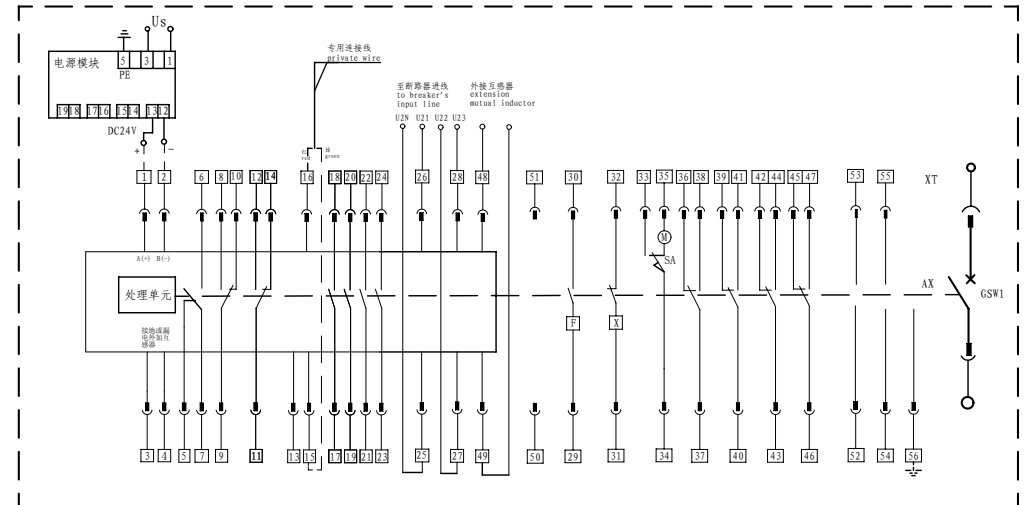

- 注: (1) 1、2端子: 接智能控制器外供电电源DC24V, DC24V电源需通过电源模块供电。
 (2) 3、4为外加接地或漏电互感器。
 (3) 对于5、6、7、8、9、10、11、12、14、29、30、31、32端用户不可使用, 不可作任何输入、输出点。
 (4) 17-24为可编程输入/输出接口, S1型、S2型、S3型。
 (5) 25-28为备用电压输入信号, 依次接入U2N、U21、U22、U23, 接线相序需正确, L2N必须接入。
 (6) 15、16分别为RS485A, RS485B通讯引出线, 13为通讯屏蔽接地线。
 (7) 56接保护地线。
 (8) 29-30为分励脱扣器, 31-32为闭合电磁铁。
 (9) 33-34-35接储能电动机, 34、35接AC220V电源。
 (10) 当选用3P+N型断路器时, 48、49为外接N相互感器输入端。

- note: (1) terminal 1, 2: wire the extension power for intelligent controller, wire for charging motor the type is: AC220V.
 (2) terminal 3, 4: wire the extension earthed or leak current mutual inductor
 (3) Users don't used terminal for 5, 6, 7, 8, 9, 10, 11, 12, 14, 29, 30, 31, 32. don't used as enter and output.
 (4) terminal 17-24: programable I/O interface, type: S1, S2, S3
 (5) terminal 25-28: reserve voltage signal input, must be wire of normal power L2N, L21, L22, L23 phase corresponding, wiring serial must be correct and the L2N-phase must be wired.
 (6) terminal 15, 16: wiring RS485A, RS485B correspondence line respectively; 13: earthed terminal
 (7) earthed terminal: 56
 (8) terminal 29-30: shunt release, terminal 31-32: closing electromagnet.
 (9) terminal 33-34-35: motor-driven energy-storage system, 34, 35 must be AC220V.
 (10) when breaker chosen as the type of 3P+N, the extension n-phase mutual inductor's signal inputs terminal 48, 49 power supply-different power supply for different rated voltage of intelligent controller, F, X, M etc.

GSAl-1600/H (通信型) 自动转换开关常用断路器、备用断路器二次接线电气连接图

Wiring diagram of second circuit equipped for normal breaker and standby breaker of GSAl-1600/H frame automatic transfer switching system

常用断路器二次接线电气连接图
Wiring diagram of second circuit equipped for normal breaker

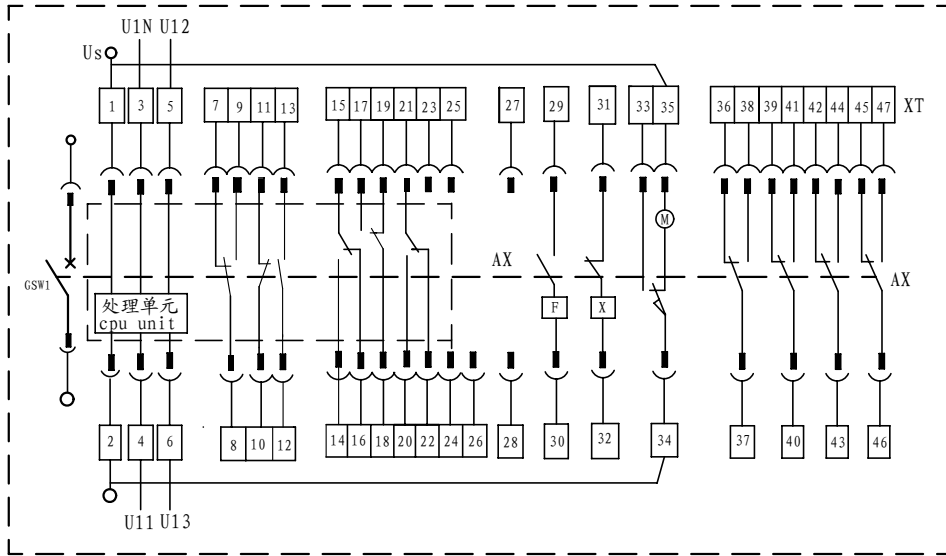

- 注:
- (1) 对于7、8、9、10、11、12、13、29、30、31、32端用户不可使用，不可作任何输入、输出点。
 - (2) 1、2端子：为智能控制器外供电电源，必须接AC220V电源，34、35为电机储能端子，必须接AC220V电源。
 - (3) 3、4、5、6端子为常用电源L1N、L11、L12、L13相，接线顺序需正确，L1N极必须接入。
 - (4) 14-15、15-16为负载监控方式一或方式二时，负载一越限输出信号。
17-18、18-19为负载监控方式一或方式二时，负载二越限输出信号。
20-21、21-22为负载监控方式二时，负载二恢复信号。
 - (5) 25、27、28为备用触点。26为接地触点。
 - (6) 29-30为分励线圈，31-32为闭合电磁铁，33-34-35为储能电动机。
 - (7) 36-47为辅助触头（触头容量AC220V，9A）。
 - (8) 当选用3P+N型断路器时，23、24为外接N相互感器输入端。
AX为断路器辅助开关；XT为断路器二次接线端子；F为分励脱扣器；X为闭合电磁铁；M为储能电机。

- note:
- (1) Users don't used terminal for 7、8、9、10、11、12、13、29、30、31、32. don't used as enter and output.
 - (2) terminal 1、2: wire the extension power for intelligent controller, terminal 34、35: wire for charging motor, the type is: AC220V.
 - (3) terminal 3、4、5、6 must be wire of normal power L1N、L11、L12、L13 phase corresponding, wiring serial must be correct and the L1N-phase must be wired.
 - (4) at the load-monitor pattern 1 or 2, 14-15, 15-16 output the load 1 overranging signal.
at the load-monitor pattern 1 or 2, 17-18, 18-19 output the load 2 overranging signal.
at the load-monitor pattern 2, 20-21, 21-22 output the load 2 returning signal.
 - (5) standby terminal: 25、27、28. earthed terminal: 26
 - (6) terminal 29-30: shunt release, terminal 31-32: closing electromagnet, terminal 33-34-35: motor-driven energy-storage system.
 - (7) auxiliary terminal: 36-47.
 - (8) when breaker chosen as the type of 3P+N, the extension n-phase mutual inductor's signal inputs terminal 23、24.
AX-auxiliary switch of the breaker; XT-terminal of secondary circuit if breaker;
F-shunt release; X-closing electromagnet; M-charging motor.

备用断路器二次接线电气连接图
Wiring diagram of second circuit equipped for reserve breaker

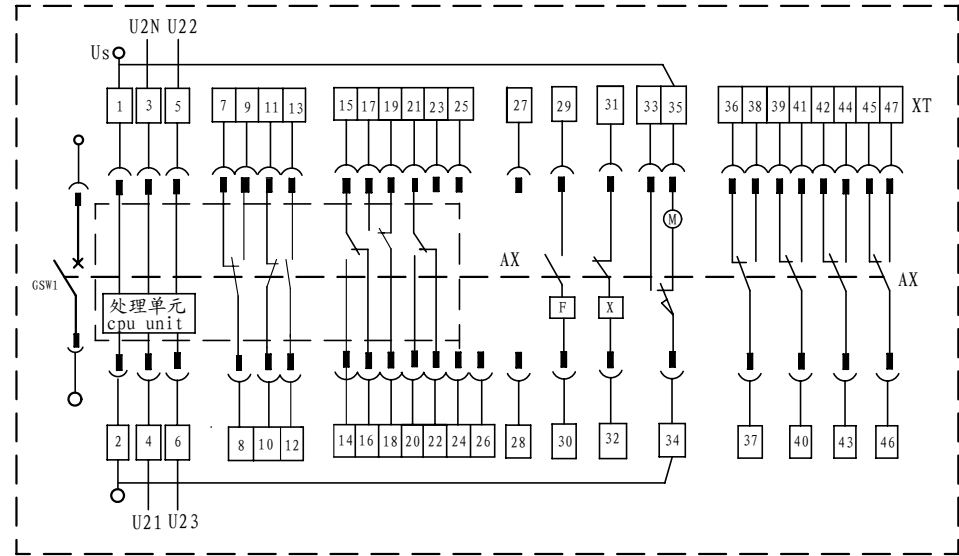

- 注:
- (1) 对于7、8、9、10、11、12、13、29、30、31、32端用户不可使用，不可作任何输入、输出点。
 - (2) 1、2端子：为智能控制器外供电电源，必须接AC220V电源，34、35为电机储能端子，必须接AC220V电源。
 - (3) 3、4、5、6端子为备用电源L2N、L21、L22、L23相，接线顺序需正确，L2N极必须接入。
 - (4) 14-15、15-16为负载监控方式一或方式二时，负载一越限输出信号。
17-18、18-19为负载监控方式一或方式二时，负载二越限输出信号。
20-21、21-22为负载监控方式二时，负载二恢复信号。
 - (5) 25、27、28为备用触点。26为接地触点。
 - (6) 29-30为分励线圈，31-32为闭合电磁铁，33-34-35为储能电动机。
 - (7) 36-47为辅助触头（触头容量AC220V，9A）。
 - (8) 当选用3P+N型断路器时，23、24为外接N相互感器输入端。
AX为断路器辅助开关；XT为断路器二次接线端子；F为分励脱扣器；X为闭合电磁铁；M为储能电机。

- note:
- (1) Users don't used terminal for 7、8、9、10、11、12、13、29、30、31、32. don't used as enter and output.
 - (2) terminal 1、2: wire the extension power for intelligent controller, terminal 34、35: wire the charging motor, the type is: AC220V.
 - (3) terminal 3、4、5、6 must wire reserve power L2N、L21、L22、L23 phase corresponding, wiring serial must be correct and the L2N-phase must be wired.
 - (4) at the load-monitor pattern 1 or 2, 14-15, 15-16 output the load 1 overranging signal.
at the load-monitor pattern 1 or 2, 17-18, 18-19 output the load 2 overranging signal.
at the load-monitor pattern 2, 20-21, 21-22 output the load 2 returning signal.
 - (5) standby terminal: 25、27、28. earthed terminal: 26
 - (6) terminal 29-30: shunt release, terminal 31-32: closing electromagnet, terminal 33-34-35: motor-driven energy-storage system.
 - (7) auxiliary terminal: 36-47.
 - (8) when breaker chosen as the type of 3P+N, the extension n-phase mutual inductor's signal inputs terminal 23、24.
AX-auxiliary switch of the breaker; XT-terminal of secondary circuit if breaker;
F-shunt release; X-closing electromagnet; M-charging motor.

GSA1-2000、3200、4000、6300/L、M自动转换开关常用断路器、备用断路器二次接线电气连接图

Wiring diagram of second circuit equipped for normal breaker and standby breaker of GSA1-2000、3200、4000、6300/L、M frame automatic transfer switching system

常用断路器二次接线电气连接图
Wiring diagram of second circuit equipped for normal breaker

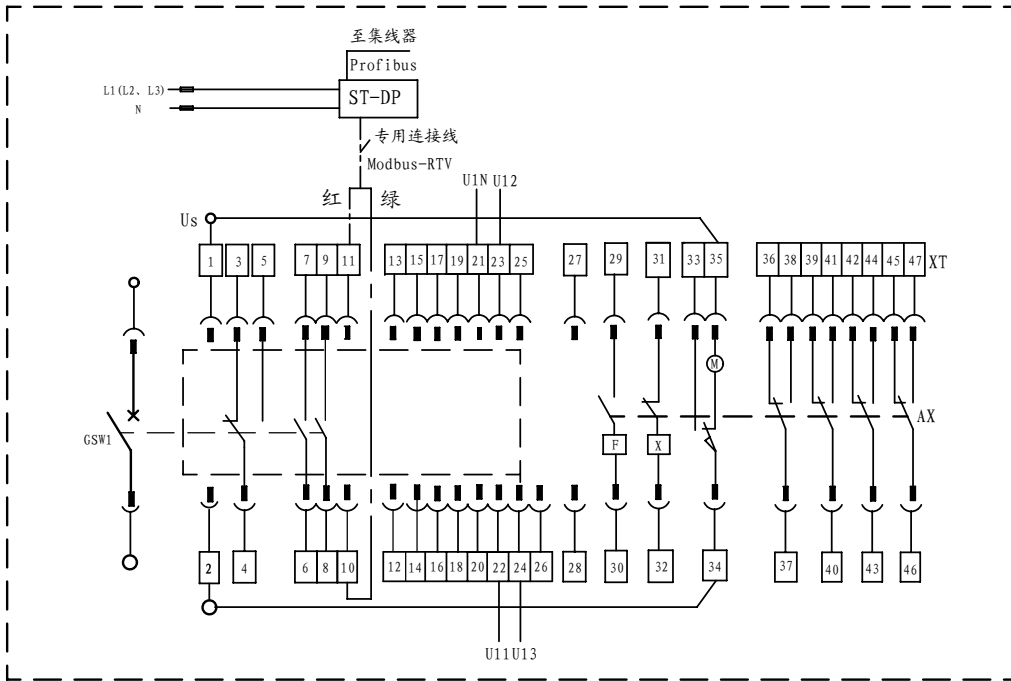

- 注:
- (1) 对于3、4、5、6、7、8、9、29、30、31、32端用户不可使用，不可作任何输入、输出点。
 - (2) 1、2端子：为智能控制器外供电源，必须接AC220V电源。
 - (3) 21、22、23、24端子为常用电源L1N、L11、L12、L13的电压信号输入端，接线顺序需正确，L1N极必须接入。
 - (4) 12-13、14-15、16-17、18-19端子控制四组信号触点输出。
 - (5) 20为保护接地触点。
 - (6) 29-30为分励线圈，31-32为闭合电磁铁，
 - (7) 33-34-35为储能电动机，34、35接AC220V电源。
 - (8) 36-47为辅助触头（触头容量AC220V，9A）。
 - (9) 当选用3P+N型断路器时，25、26为外接N相互感器输入端。
 - (10) 10、11分别为RS485A、RS485B通信引出线。

- note:
- (1) Users don't used terminal for 3、4、5、6、7、8、9、29、30、31、32. don't used as enter and output.
 - (2) terminal 1、2:wire the extension power for intelligent controller,the type is:AC220V.
 - (3) terminal 21、22、23、24 must are wire of normal power LN、L11、L12、L13 phase corresponding,wiring serial must be correct and the L1N-phase must be wired.
 - (4) termioal 12-13、14-15、16-17、18-19control 4 Paris of signal outputting.
 - (5) earthed terminal:20
 - (6) terminal 29-30:shunt release, terminal 31-32:closing electromagnet.
 - (7) terminal 33-34-35:motor-driven energy-storage system.34、35 must be AC220V.
 - (8) auxiliary terminal:36-47.
 - (9) when breaker chosen as the type of 3P+N,the extension n-phase mutual inductor's signal inputs terminal 25、26.
 - (10) terminal 11、12: wiring RS485A,RS485B correspondence line respectively.

备用断路器二次接线电气连接图
Wiring diagram of second circuit equipped for reserve breaker

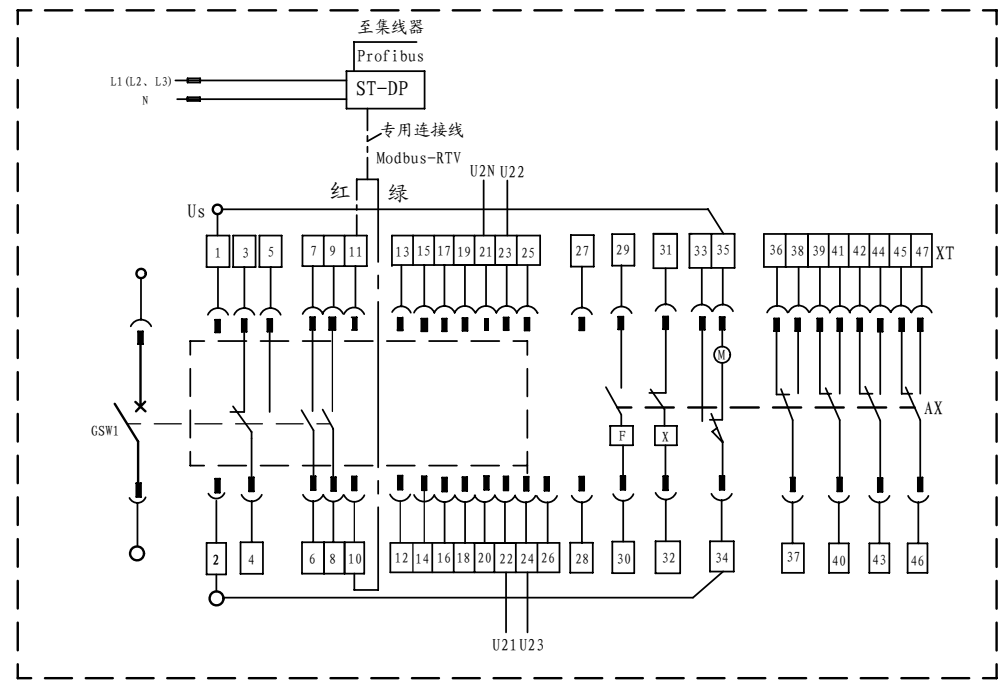

- 注:
- (1) 对于3、4、5、6、7、8、9、29、30、31、32端用户不可使用，不可作任何输入、输出点。
 - (2) 1、2端子：为智能控制器外供电源，必须接AC220V电源。
 - (3) 21、22、23、24端子为备用电源L2N、L21、L22、L23的电压信号输入端，接线顺序需正确，L2N极必须接入。
 - (4) 12-13、14-15、16-17、18-19端子控制四组信号触点输出。
 - (5) 20为保护接地触点。
 - (6) 29-30为分励线圈，31-32为闭合电磁铁，
 - (7) 33-34-35为储能电动机，34、35接AC220V电源。
 - (8) 36-47为辅助触头（触头容量AC220V，9A）。
 - (9) 当选用3P+N型断路器时，25、26为外接N相互感器输入端。
 - (10) 10、11分别为RS485A、RS485B通信引出线。

- note:
- (1) Users don't used terminal for 3、4、5、6、7、8、9、29、30、31、32. don't used as enter and output.
 - (2) terminal 1、2:wire the extension power for intelligent controller,the type is:AC220V.
 - (3) terminal 21、22、23、24 must are wire of reserve power L2N、L21、L22、L23 phase corresponding,wiring serial must be correct and the L2N-phase must be wired.
 - (4) termioal 12-13、14-15、16-17、18-19control 4 Paris of signal outputting.
 - (5) earthed terminal:20
 - (6) terminal 29-30:shunt release, terminal 31-32:closing electromagnet.
 - (7) terminal 33-34-35:motor-driven energy-storage system.34、35 must be AC220V.
 - (8) auxiliary terminal:36-47.
 - (9) when breaker chosen as the type of 3P+N,the extension n-phase mutual inductor's signal inputs terminal 25、26.
 - (10) terminal 11、12: wiring RS485A,RS485B correspondence line respectively.

GSA1-2000、3200、4000、6300/ H (通信型) 自动转换开关常用断路器、备用断路器二次接线电气连接图

Wiring diagram of second circuit equipped for normal breaker and standby breaker of GSA1-2000、3200、4000、6300/H frame automatic transfer switching system (correspondence)

GSA1-2000 M R / 3 1600A 抽屉式 附件说明

1 2 3 4 5 6 7

- 1... 断路器框架等级电流: 2000A 3200A 4000A 6300A
Frame Rated Current: 2000A 3200A 4000A 6300A
- 2... 能力级别: L型、M型、H型
Ability class: M type、L type、H type
- 3... 控制方式: R型、S型、F型
Control ways: R type、S type、F type
- 4... 极数: 3P、4P、3P+N
Poles: 3P、4P、3P+N
- 5... 断路器额定工作电流:
Rated Current:
1600型额定工作电流为: 200A、400A、800A、1250A、1000A、1250A、1600A;
Rated Current of 1600: 200A、400A、800A、1250A、1000A、1250A、1600A;
2000型额定工作电流为: 630A、800A、1000A、1250A、1600A、2000A;
Rated Current of 2000: 630A、800A、1000A、1250A、1600A、2000A;
3200型额定工作电流为: 2000A、2500A、3200A;
Rated Current of 3200: 2000A、2500A、3200A;
4000型额定工作电流为: 4000A (增容型);
Rated Current of 4000: 4000A (enhance capacity type)
6300型额定工作电流为: 4000A、5000A、6300A;
Rated Current of 6300: 4000A、5000A、6300A;
- 6... 安装方式: 抽屉式和固定式
Installation Pattern: draw-out and fixed
- 7... 附件说明: 见表14
Attachment instruction : see table 14

(请在 内填数字, 在 内打
(Please fill figures in
or sign in)

表 14 table 14

用户单位 name			订货台数 order amount			订货日期 date		
型号 type	GSA1- <input type="text"/>							
极数 pole	<input type="checkbox"/> 3P		<input type="checkbox"/> 4P		<input type="checkbox"/> 3P+N			
额定电压 rated voltage	<input type="checkbox"/> AC400V							
额定电流 rated current	In = <input type="text"/> A		N极额定电流 rated current of N pole		<input type="checkbox"/> 0.4Ir1		<input type="checkbox"/> 1.0Ir1	
安装方式 type of installation	固定式 <input type="checkbox"/> fixed		抽屉式 <input type="checkbox"/> draw-out					
智能控制器 intelligent controller	类型选择 type choosing		<input type="checkbox"/> 3L		<input type="checkbox"/> 3M		<input type="checkbox"/> 3H	
	基本功能 basic function		过载长延时保护 overload long-time delay		短路短延时保护 shortcircuit short-time delay		短路瞬时保护 short circuit instantaneous	
			Ir1 <input type="text"/> A t1 <input type="checkbox"/> S		Ir2 <input type="text"/> A t2 <input type="checkbox"/> S		Ir3 <input type="text"/> A	
			接地故障保护 earthed error					
选择功能 choosing function		<input type="checkbox"/> 负载监控 load monitoring		<input type="checkbox"/> 方式一 pattern one		<input type="checkbox"/> 方式二 pattern two		
必备附件 attachments	辅助开关 auxiliary switch		<input type="checkbox"/> 标准型 normal type		<input type="checkbox"/> 4常开4常闭 4NC4NO			
			<input type="checkbox"/> 特殊型 special type	<input type="checkbox"/> 6常开2常闭 6NC2NO	<input type="checkbox"/> 2常开6常闭 2NC6NO	<input type="checkbox"/> 3常开3常闭 3NC3NO	<input type="checkbox"/> 5常开5常闭 5NC5NO	<input type="checkbox"/> 6常开6常闭 6NC6NO
机械联锁 machine interlock		<input type="checkbox"/> 钢缆联锁 cable interlock		<input type="checkbox"/> 联杆联锁 rod interlock				
选择附件 accessory	<input type="checkbox"/> 外接N相电流互感器 extension N-phase mutual inductor				<input type="checkbox"/> 安装框 installation frame			
备注 note	如用户订货的产品技术要求超过本规范表, 请与本厂协商解决 if users order with technical demands beyond range of this order form, please contact with us							